

The Application Note is pertinent to the Quantum III/Mentor II Family

Dual Stopping Rates

Quite often there is a need for 2 deceleration rates when using motor drives. Usually there is a normal stop rate and the need for an occasional Fast or quick decel stopping rate. The ability of a DC Drive to stop a motor quickly usually means that a Regenerative model drive is required. This application note will address how one might create dual stopping rates.

On a Stop command the drive will ramp to stop using the default decel rate which is contained in parameter #2.05 (decel rate #1). You can refer to the diagram of Menu 2 shown below. There 2 decel rates available. We would use Decel #2 or #2.09 for our alternate rate, but how can it be selected? Obviously, we will need an input to tell the drive when to use this alternate rate. This can be accomplished if we can change the position of the deceleration rate selector- #2.18.

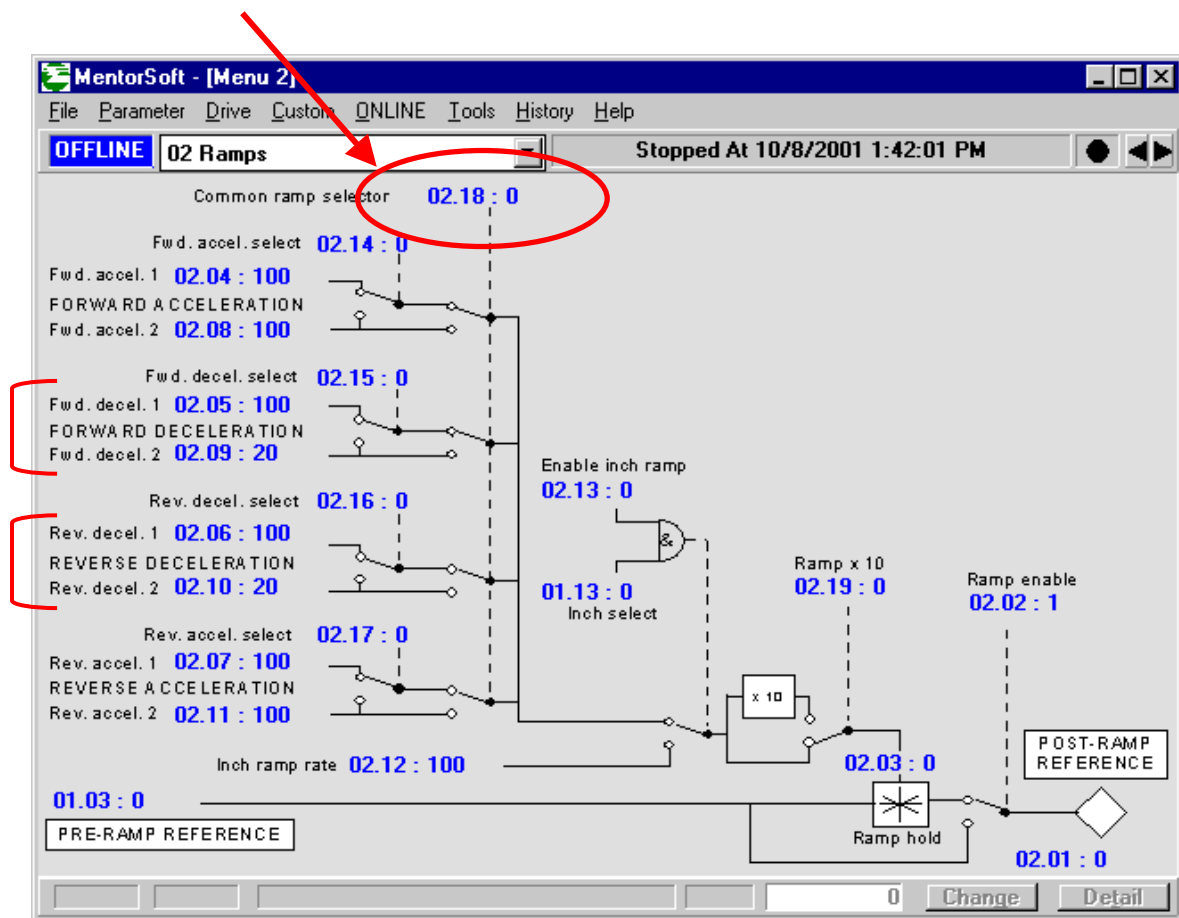

Note: For Regenerative Drive Models and where both forward and reverse motor directions are being utilized, there is a separate set of decel rates that would come into play in the reverse direction- namely #2.06 and #2.10.

Uni-Directional Applications

If we assign one of the unused programmable inputs to control #2.18, we'll just about have it. If you have a Regen model but do not use the Forward/Reverse input or if you have a Non-Regen model, the Forward/Reverse input (pin 11 of TB1 on the 115vac Interface Board) would be free for use as the Fast Stop input. In this case, you would merely change parameter #8.14 from 112 to 218 and refer to the Physical Connections section of this App Note. Whenever configuration changes are made, you must depress reset for them to take effect.

Bi-Directional Applications

If you have a Regen model and use the Forward/Reverse input, you could re-configure the Drive Reset input (pin 12 of TB1 on the 115vac Interface Board) for use as the Fast Stop input. This input is shipped from the factory as an External Fault Reset function. If this is not needed, this input would be ideal for this purpose. In this case, you would merely change parameter #8.15 from 115 to 218. Whenever configuration changes are made, you must depress reset for them to take effect.

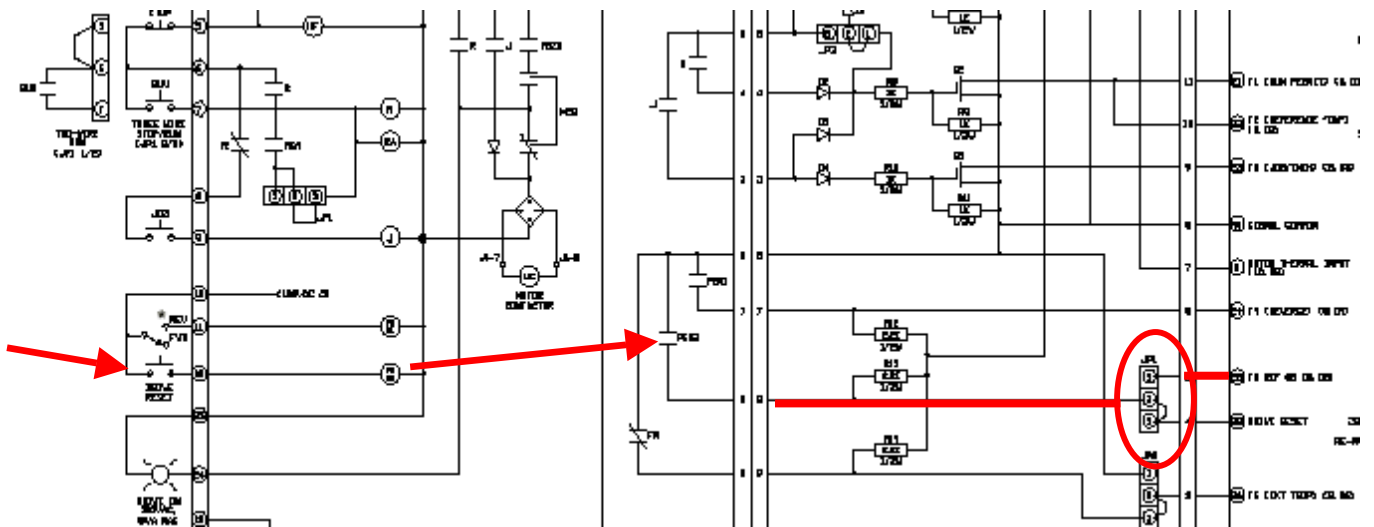

Quantum III Manual March 2002 page 37 or 212 Interconnect Diagram segment

In addition, when re-configuring the Reset input for something other than Reset, jumper JP1 of the Logic Interface Board (9500-4030) must be moved to the 1-2 position.

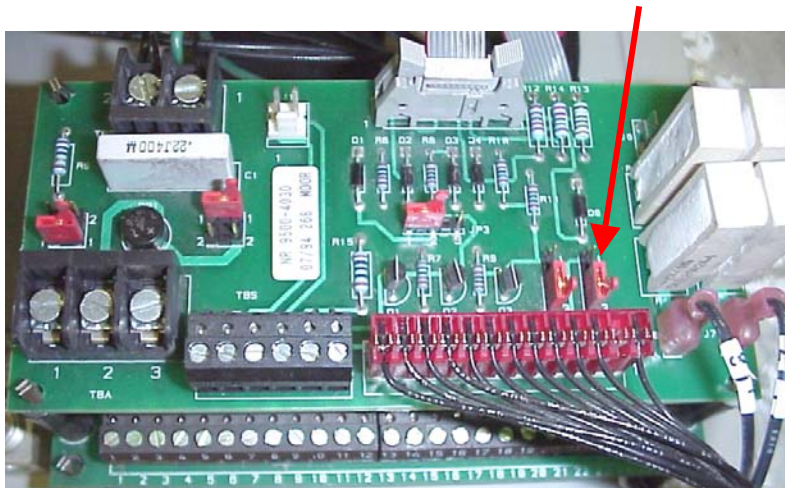

Physical Connections for Quantum III

The hookup below (3-wire scenario) uses a momentary Run contact to cause the Drive to go into the Run Mode and either of the Stop buttons will unlatch the Run condition. The key to having a dual Stop rate is having the additional contact block on the Quick Stop pushbutton. The button shown here is the Push-In/ Pull Out type that will maintain the closure on the NO (normally open) block when Quick Stop is commanded thereby maintaining the selection of the second decel rate which we have designated as our Fast rate. For normal Stop, our Fast rate input will not be selected thereby selecting the normal Stop rate setting in parameter #2.05. We would place our Fast Stop rate in parameter #2.09.



115vac Run/Stop Wiring
connected to 9500-4025
Relay Logic Board TB1

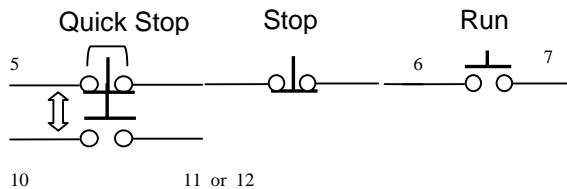
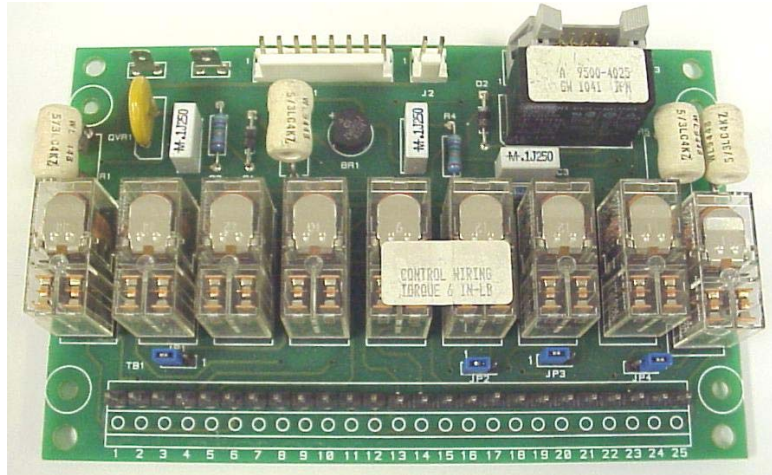

11 if Reverse is not required
12 if Remote Reset is not required

Note: This application note does not intend to imply that this method can be used to satisfy the Industrial Standards concerning the definition of EMERGENCY STOP. One should consult OSHA or other machine safety standards concerning EMERGENCY STOP and the required criteria.

Consult all NEC and OSHA machine safety recommendations and guidelines.

APPLICATION SAFETY

When applying a motor drive in a manufacturing process, one must understand that the motor drive merely provides the energy for a motor to turn and it will do so without regard upon activation and command. There could be failure modes in any external interface equipment and/or the Drive itself that could cause the motor to turn suddenly at any speed or cause it to fail to stop on command without warning. When considering Operator safety **the Installer must** include and employ additional equipment to provide safeguards to insure Operator safety. Typically this involves the topic of **EMERGENCY STOPPING**.

Consult all NEC and OSHA machine safety recommendations and guidelines.

Below are a few helpful links to associated topics:

- Click -> [ISO 13850:1996](#) is a document available from ANSI
- Click -> [OSHA Guidelines](#)
- Click -> [Plant Safety Guidelines](#)
- Click -> [Remote start/stop of drives](#)
- Click -> [EN 954-1](#) excerpts
- Click -> [Control Engineering Article](#)

Typically, Emergency Stop methods **DO NOT** utilize or depend on the motor drive to stop the motor or machine in Emergency situations. They usually employ external independent devices and/or methods to bring the motor or machine to rest in expeditious and stable manner.

These safeguards are the sole responsibility of the Installer. For these reasons, the Installer must envision all, implement all and test or simulate all failure methods. The Installer is responsible for his/her resulting implementation to insure safe and reliable operation of the installation.

In addition, the **Installer** should provide the End User of his Installed system with a System User's Manual and instruct the User/Operator on correct/safe operation. Instruction should include the demonstration and purpose of safety features that you the **Installer** have included and the importance of periodic testing to insure they do indeed operate as originally designed. The **Installer** should instruct, inform and warn his End User customer against bypassing the safety permissives the **Installer** has provided.

System Interface Suggestions

A fundamental basic system interface suggestion would be to always employ a method to supply a “permissive” or System Enable to allow the drive system to work if all things on the machine are alright. This interface would provide a method to keep the System disabled if certain key safety permissives are not satisfied. The **installer** should instruct, inform and warn his End User customer against bypassing the safety permissives the Installer has provided. The System Enable function would also have the ability to disable the drive if it was in operation and some safety device were tripped or if the Operator encountered a need to request an Emergency Stop for instance.

The external relay logic system outlined below would provide a basic yet effective method of supplying an overall System Enable for a Drive installation.

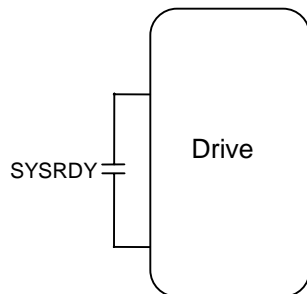
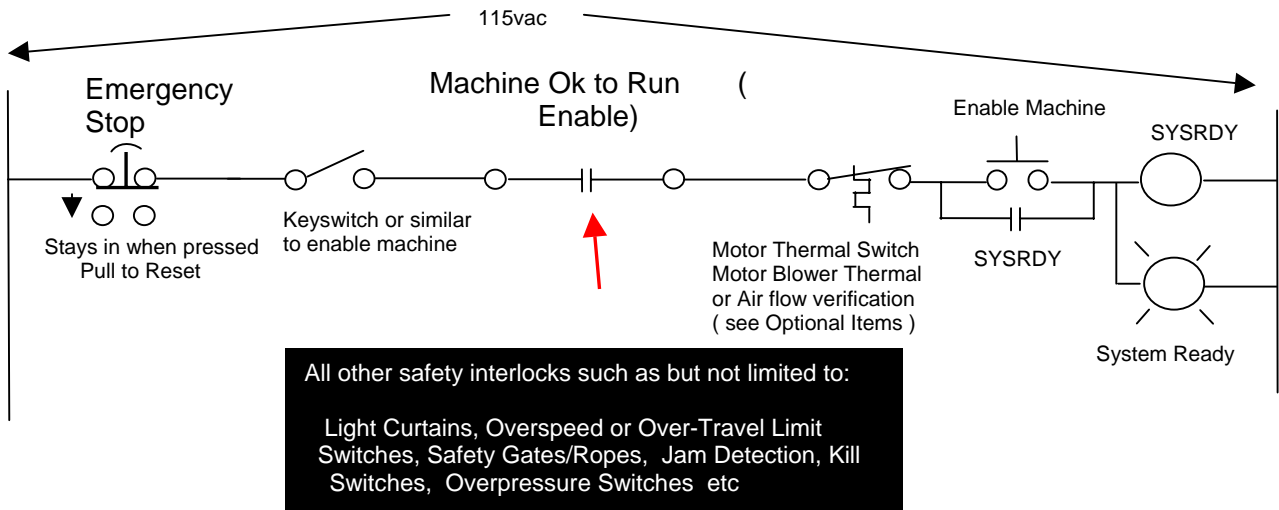

A contact from the SYSRDY (System Ready) relay above would become contact for the Drive Enable(s).

For Quantum III Drives- pins 1-4 on AC Interface
For Mentor II Drives- pins 31-40 on TB4 (for neg logic)

For Quantum III Drives the items listed or shown in the ladder example rung above can be placed between terminals 1-4 on the 9500-4025 AC Interface Board. See Quantum III Interconnect diagram for details.

From above, the **Machine OK to Run**, can be a composite of a wide range of safety interlocking devices. Typically these devices provide a **closed contact** if the safety condition that they are monitoring is ok or within limits. These may include but are not limited to:

Light curtains- a light beam that when cut indicates a person has entered an area of safety concern

Safety Ropes- a rope, that when tripped over, disturbed or moved, opens a switch

Safety Gate/Guard switch- a switch placed on a safety gate or guard that indicates a person has removed a guard, cover or opened a gate and has entered an area of safety concern

Over Travel Limit Switches- a switch placed at the ends of a machine that indicate the machine has traveled erroneously beyond normal limits and must be shutdown or stopped quickly.

Kill Switches- a switch provided for the Operators, Maintenance or any other person who is near a machine to shut it down. Typically these are placed throughout the machine for ease of access. Some may be automatic in nature. For example,

- if one removes their hands from the controls a kill switch may be activated
- if one falls down or moves away from an Operator position a kill switch may be activated

Over Speed Limit Switches- a switch that indicates the machine has exceeded a safe design speed limit erroneously and deemed “out of control” and must be shutdown. Sometimes these are in the form of centrifical switches mounted on the end shaft of a motor or piece of machine.

E-Stop Pushbuttons -- (Emergency Stop) typically a large Red mushroom head button that opens a Normally closed contact which would cause a system to shutdown. They are commonly placed throughout the machine for ease of access. Typically, this E-Stop function, activates some for of rapid shutdown mechanisms that will cause the machine to halt in a short period of time. These shutdown mechanisms may include Friction Brakes, DB resistors on DC Drives or other combinations that would bring the mechanical system to a s Stop and place it in a more stable safe condition.

A safer E-Stop pushbutton type are those that when pushed in –stay in- and require to be pulled out to reset them.

Field Loss Detection- On Systems with DC motors, the Loss of Field excitation can cause a motor to rapid accelerate to unsafe speeds. For this reason, a method of Field Loss detection should be incorporated in any good System design.

***** Optional Items**

Although Motor Thermal switches, Blower motor starter overloads, air flow vane switches and similar items are sometimes inserted in this System Ready string, these items could be considered non-emergency situations and could be inserted in the normal Drive Stop string versus the System Ready string. In the case of Motor Thermal switches etc, one should insure that Field Excitation is setup to reduce to a low value should a thermal switch be used to Stop or trip the drive. One must test and verify that this does indeed function properly.

Questions ?? Ask the Author:

Author: Ray McGranor
(716)-774-0093

e-mail : ray.mcgranor@emersonct.com