

The Application Note is pertinent to the Quantum III / Mentor II, Unidrive Classic, Unidrive SP and Commander GP20 Drive Families

### **Creating a Flashing Light or Pulsing Output Contact**

There is no dispute that a blinking light catches an Operators eye better than a steady illumination. Often times you would like to have a flashing light to indicate when the drive is in the Overload condition or in Current Limit perhaps or when the drive experiences a fault trip of some kind. Or maybe you would like a beeper for when Reverse is activated –( like in many industrial vehicles today ). You could program one of the programmable outputs for the one of the above conditions to illuminate a lamp but it would not flash it. Obviously, you could purchase a flasher module of some sort and wire it in to do the job but if you knew how, you could create your own flasher within the drive itself at no additional cost ! You could even bring a contact into the drive and use its facilities to pulse an output based on your external input – the drive won't care! No cost is always a preferable solution.

#### **Implementation**

What we can do is use the built-in ( rarely utilized ) programmable logic gates within our drives to create what they used to call in the old days – an astable multi-vibrator ( *kind of kinky by today's vernacular* ).

Our 3 phase AC Unidrive Classic, Unidrive SP, Commander GP20, Commander SK and DC Quantum III/Mentor II drives contain 2 free programmable logic gates with output time delays that can be found in Menu 9. By gating them with the internal drive status signal we wish to create a flashing light for and selecting the proper time delays, we can accomplish our goal.

---

The following diagrams are screen shots directly out of CTSOft , UniSOft or MentorSOft ( available free from our website ). These diagrams outline the scheme that would be used for Unidrives or for Quantum III / Mentor II Drives to help you understand the configuration ( should you wish to ). The scheme is identical but the parameter numbers change slightly.

After each drive type is a summary tables that will allow you to quickly configure either these Drives by simply programming from that table to achieve the flasher function.

## The following is for Unidrive Classic

### Gate #1

Put your bit parameter that indicates the condition you wish to flash ( beep ) here. In this example, I chose to create a blinking warning light to flash when in the Overload condition.

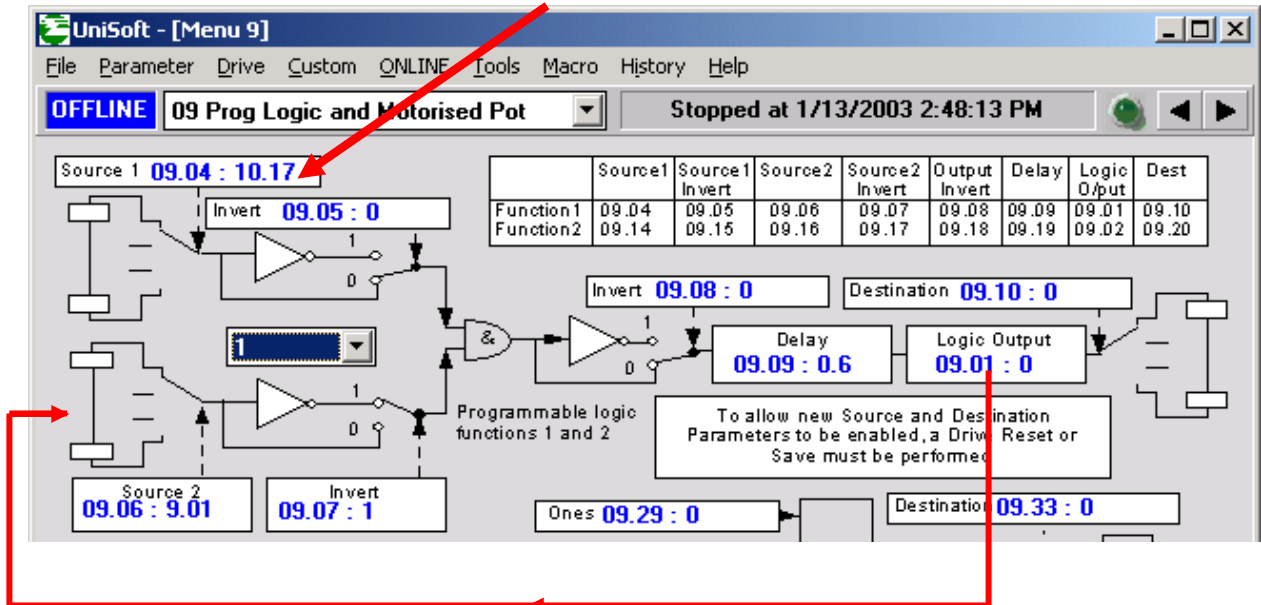

### Gate #2

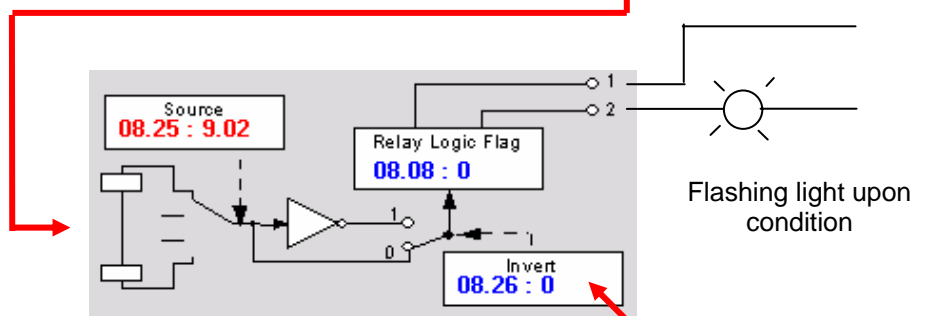
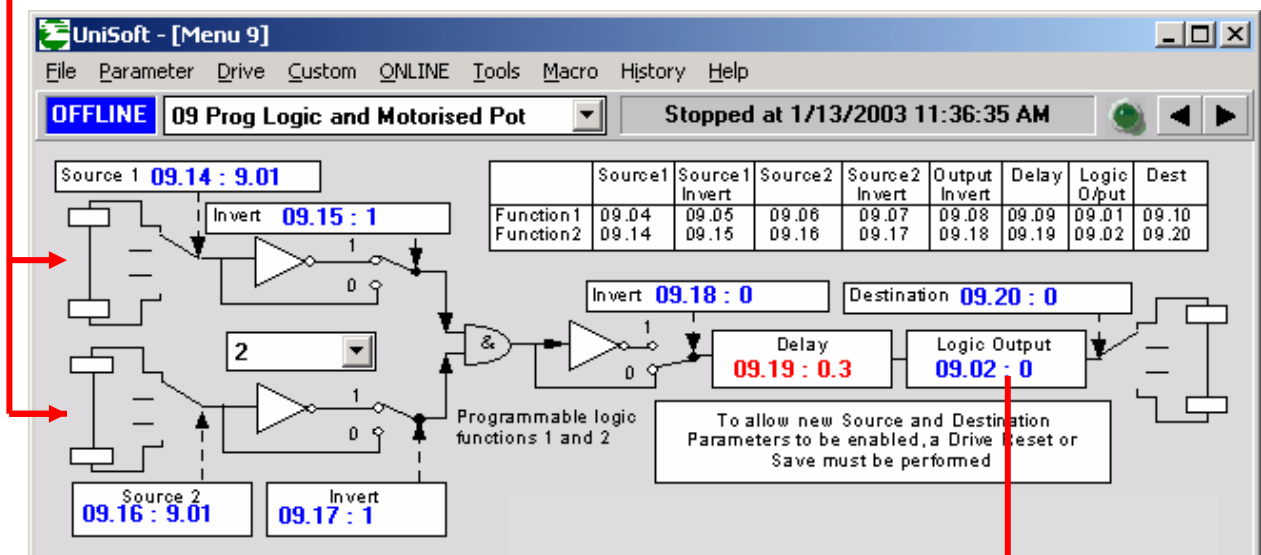

Output can be inverted for normally off state

# Flasher Quick Setup Table

This summary table will allow you to quickly configure a Unidrive Classic Drive by simply programming locations directly from that table to achieve the flasher function. Menu 10 in contains most of the status conditions that you may wish to annunciate.

## Unidrive Classic

Parameter	Setting	Comment	
#9.04	Your selected output		
#9.05	0		
#9.06	901	Feedback from output	
#9.07	1	Invert this input	
#9.08	0		
#9.09	1.0	1 second overall period	Adjustable
#9.14	901	Input from Gate 1 Output	
#9.15	1	Invert this input	
#9.16	901	Input from Gate 1 Output	
#9.17	1	Invert this input	
#9.18	0		
#9.19	0.5	0.5 seconds	Adjustable
Relay Output			Term 1-2
#8.25	902	Output of Gate 2-Flasher	
#8.26	0 or 1	Invert if necessary	

Normally you would set #9.19 to ½ of #9.09. Parameter #9.09 must be greater than #9.19. Parameter #9.09 must not be equal to #9.19 for proper operation.

# Unidrive SP and Commander GP20

Put your bit parameter that indicates the condition you wish to flash ( beep ) here. In this example, I chose to create a blinking warning light to flash when in the Overload condition.

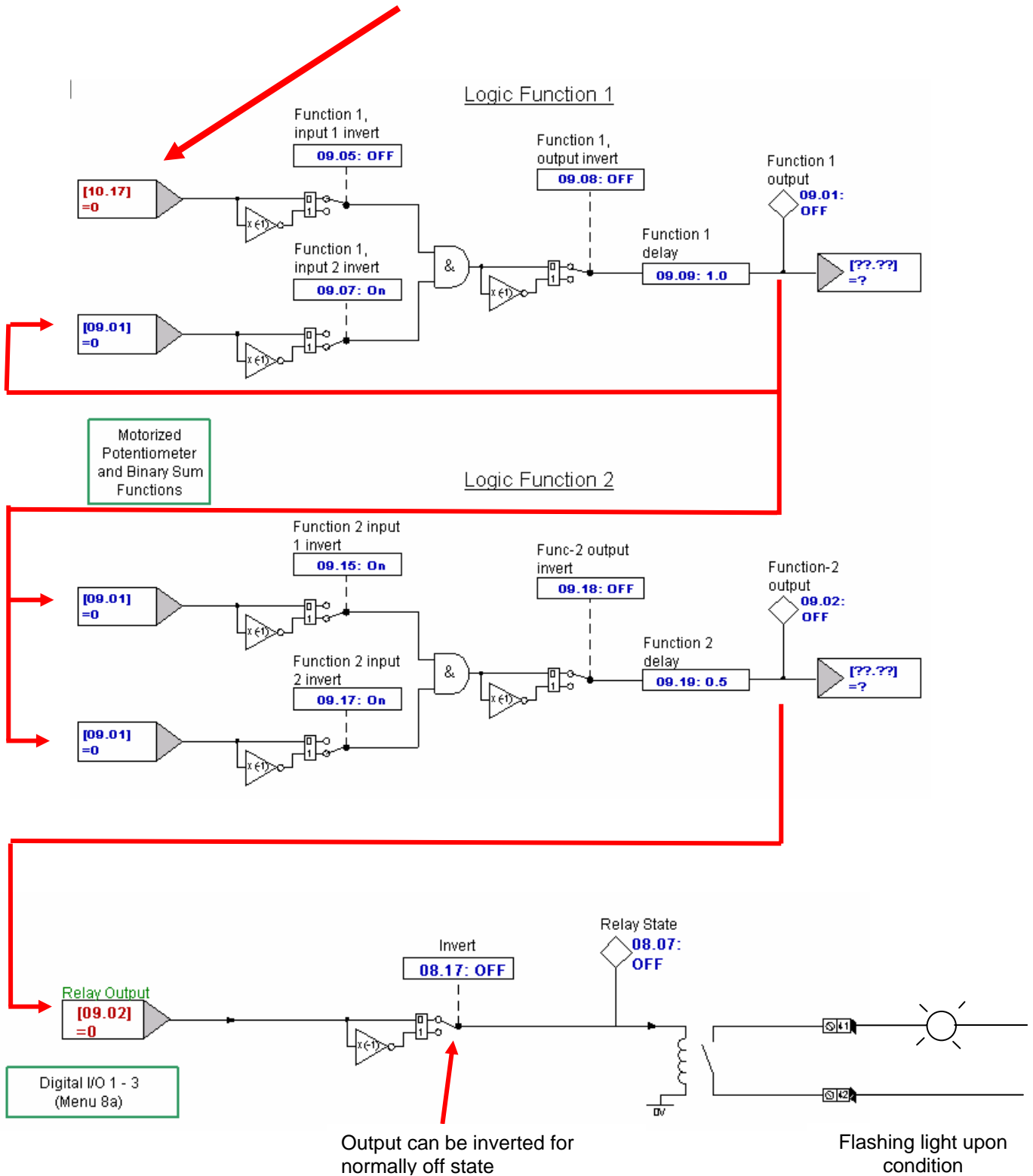

## Flasher Quick Setup Table

This summary table will allow you to quickly configure a Unidrive SP or GP20 Drive by simply programming locations directly from that table to achieve the flasher function. Menu 10 in contains most of the status conditions that you may wish to annunciate.

### Unidrive SP or GP20

Parameter	Setting	Comment	
#9.04	Your selected output		
#9.05	OFF		
#9.06	9.01	Feedback from output	
#9.07	ON	Invert this input	
#9.08	OFF		
#9.09	1.0	1 second overall period	Adjustable
#9.14	9.01	Input from Gate 1 Output	
#9.15	ON	Invert this input	
#9.16	9.01	Input from Gate 1 Output	
#9.17	ON	Invert this input	
#9.18	OFF		
#9.19	0.5	0.5 seconds	Adjustable
Relay Output			Term 41-42
#8.27	9.02	Output of Gate 2-Flasher	
#8.17	On or Off	Invert if necessary	

Normally you would set #9.19 to ½ of #9.09. Parameter #9.09 must be greater than #9.19. Parameter #9.09 must not be equal to #9.19 for proper operation.

## The following is for Quantum III/ Mentor II

### Gate #1

Put your bit parameter that indicates the condition you wish to flash ( beep ) here. In this example, I chose to create a blinking warning light to flash when in the Overload condition.

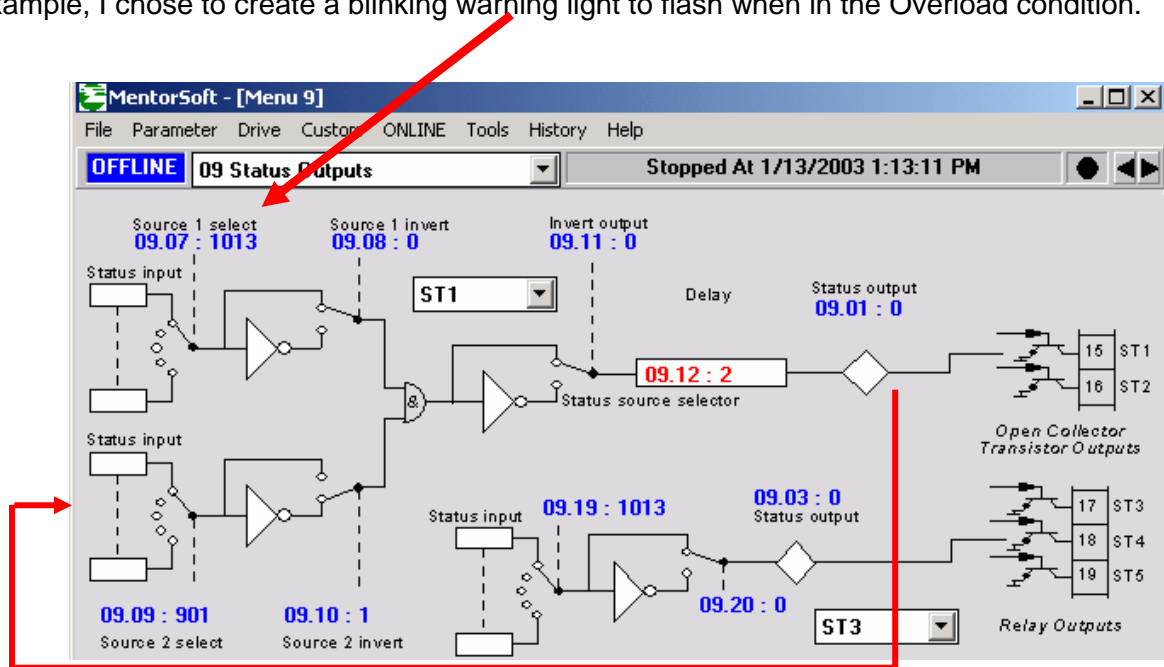

### Gate #2

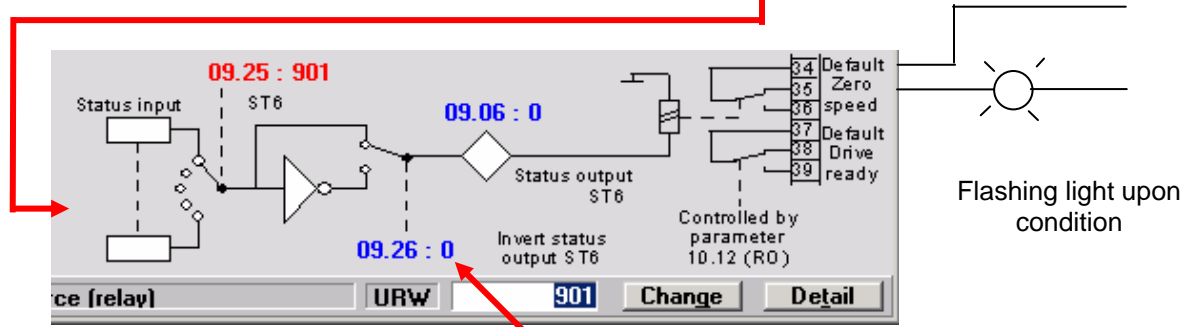
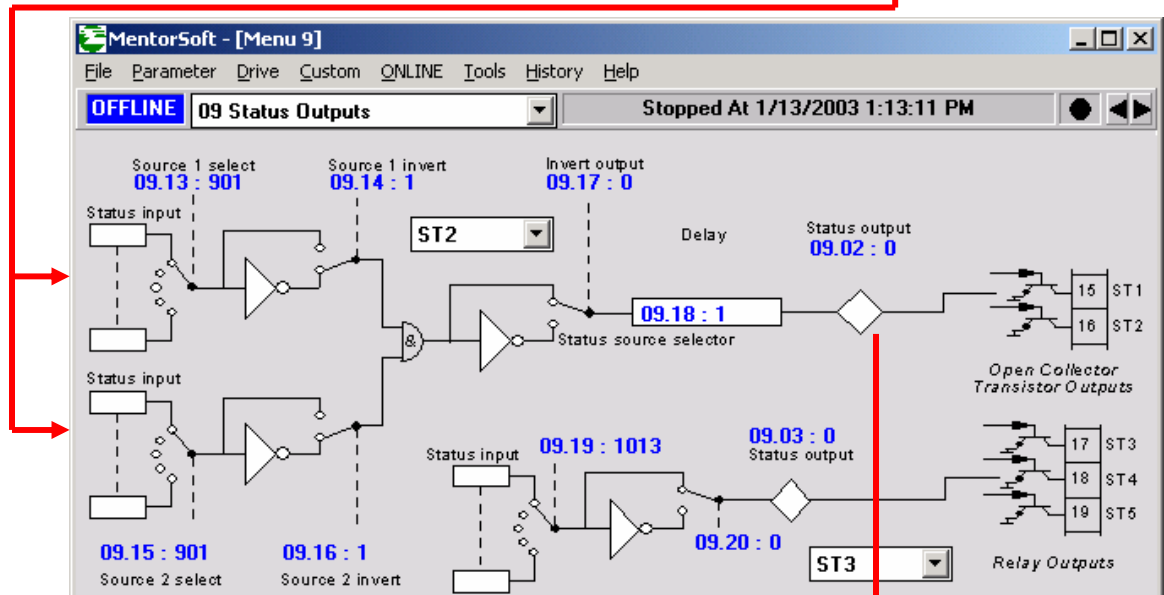

## Flasher Quick Setup Table

This summary table will allow you to quickly configure a Mentor II or Quantum III Drive by simply programming locations directly from that table to achieve the flasher function. Menu 10 in contains most of the status conditions that you may wish to announce.

### Quantum III/Mentor II

Parameter	Setting	Comment	
#9.07	Your selected output		
#9.08	0		
#9.09	901	Feedback from output	
#9.10	1	Invert this input	
#9.12	2	2 second overall period	Adjustable
#9.13	901	Input from Gate 1 Output	
#9.14	1	Invert this input	
#9.15	901	Input from Gate 1 Output	
#9.16	1	Invert this input	
#9.18	1	1 second	Adjustable
<b>Relay Output</b>			
#9.25	902	Output of Gate 2-Flasher	
#9.26	0 or 1	Invert if necessary	

Normally you would set #9.18 to ½ of #9.12. Parameter #9.12 must be greater than #9.18. Parameter #9.12 must not be equal to #9.18 for proper operation.

**Questions ?? Ask the Author:**

**Author:** Ray McGranor  
(716)-774-0093

e-mail : [ray.mcgranor@emersonct.com](mailto:ray.mcgranor@emersonct.com)