

The Application Note is pertinent to the Quantum III Family

Interfacing a PLC to the Quantum III

Long distance use of 24vdc inputs may not provide reliable operation of remote industrial pushbuttons, not to mention that it would give electrical noise a good opportunity to make its' way into the drive circuitry. For this reason, the Quantum III was designed with 115vac Run/Stop input circuitry to allow reliable, general purpose use of remote Run/Stop Industrial pushbuttons. However, in some applications, it is desirable to control a Quantum III drive with a PLC from an open collector (24vdc type) output for starting the drive. Typically in those cases, the PLC is located quite near the drive and the problems associated with long distance runs are not an issue as cited above.

As far as controlling speed, a 0 to 10vdc speed reference can be applied directly into the default speed reference input (pin #3 and #20). The start command on the other hand, will require some minor parameter changes. This application note will show how this can be achieved.

In this application, the open collector output of the PLC will control one of the "free" logic inputs of the Quantum III, F10 for example. The programmable relay contacts will be used to interface this digital input to the 120vac logic to start the drive. The function of the programmable relay defined by source parameter #9.25, (which is factory defaulted to indicate Zero Speed) is changed from 1009 (Zero Speed flag) to the F10 input status bit which is parameter #8.10. So we would set #9.25= 810 (F10 input).

Terminals #34 and #36 on the MDA2 board are the normally open relay contact which will be connected to terminals #5 and #7 of TB1 on the AC Interface board (9500-4025).

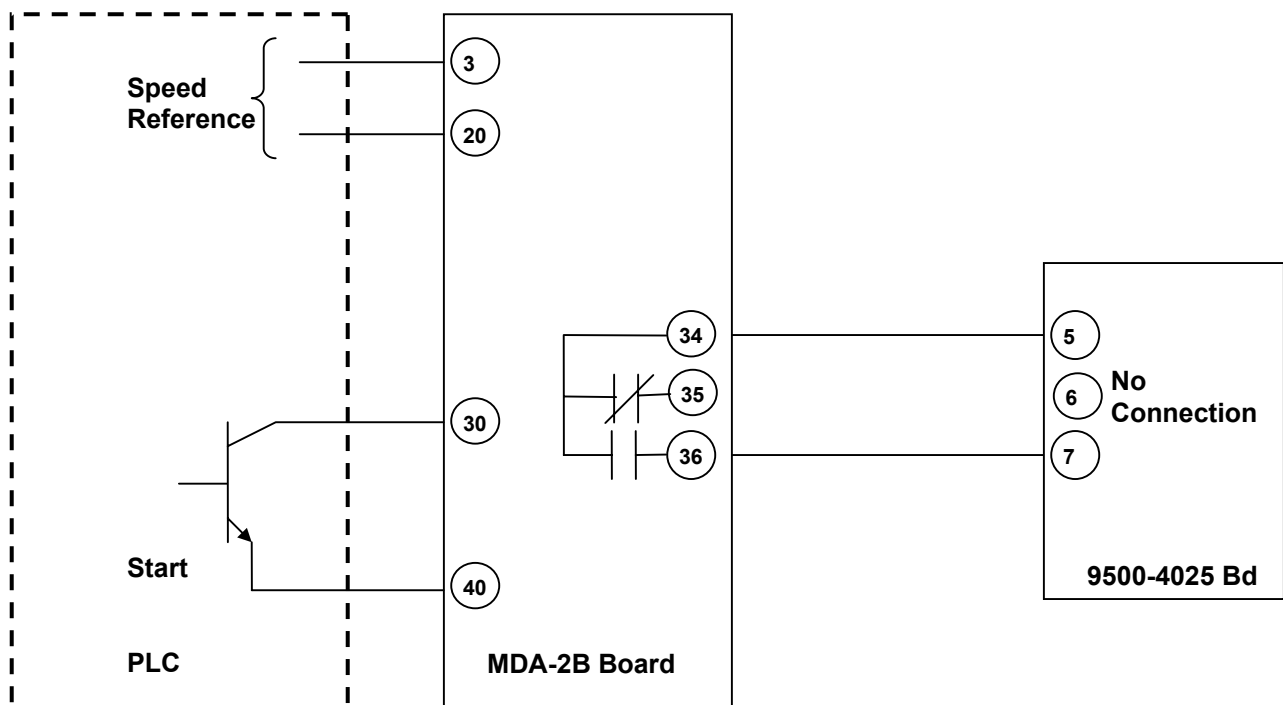

The Quantum III has a free programmable relay contact that is available for customer use on TB4 of the MDA2B Board (TB4 is under the snap on drive cover). Pins 34 and 36 of this terminal strip is the NO (normally open) contact of this relay. Factory defaults for this relay set it to activate AT ZERO SPEED, but you can set it to any other bit of your choice. In this example we set it to activate when F10 becomes a 1, which happens when, pin 30 is connected to common (under negative logic).

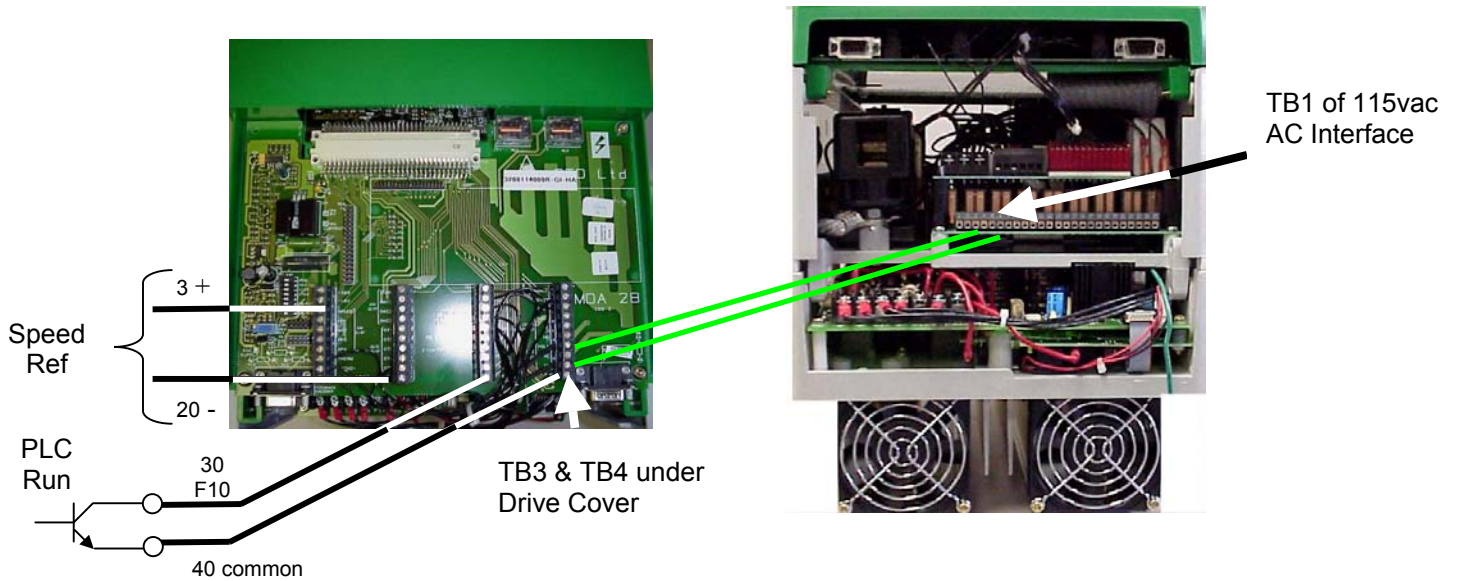

| TB4 MDA2B Board | TB1 AC Interface |
|-----------------|------------------|
| 34 | 5 |
| 36 | 7 |
| | |

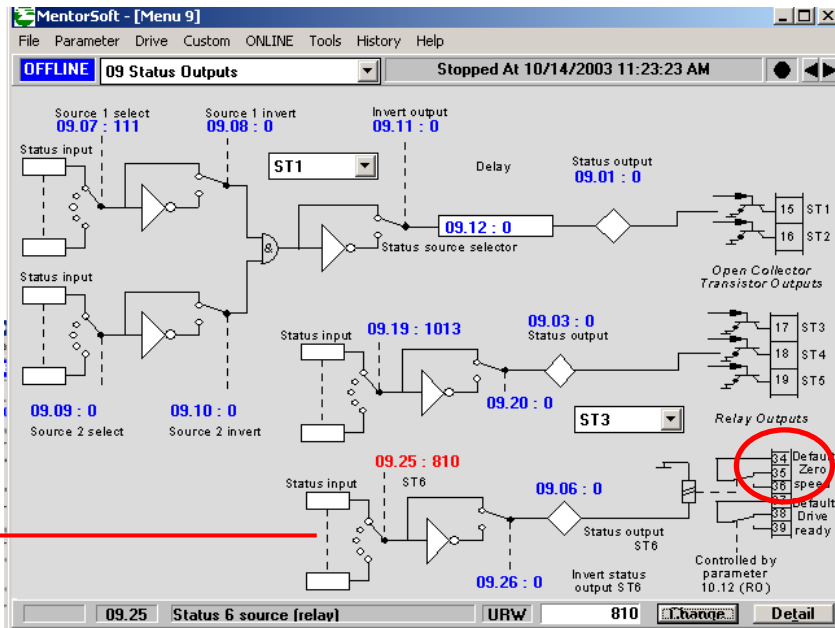
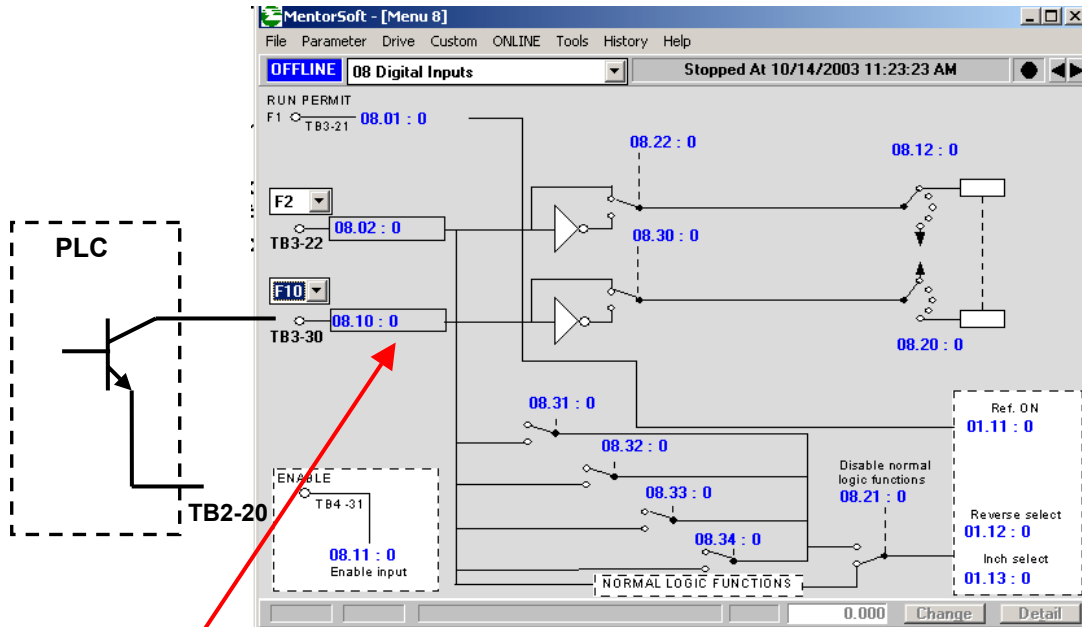

To
9500-
4025
Board

Questions: Ask the author ??

Steve Zaleski Email: <mailto:steve.zaleski@emersonct.com>

Tel: 716-774-1193