

The Application Note is pertinent to the Focus 3 Regenerative drives

Adjustable Brake / Dynamometer Applications

This application note will discuss the use and setup of Focus 3 Regenerative drives in “loading” type applications such as “brakes” for unwind stands and motor test stands.

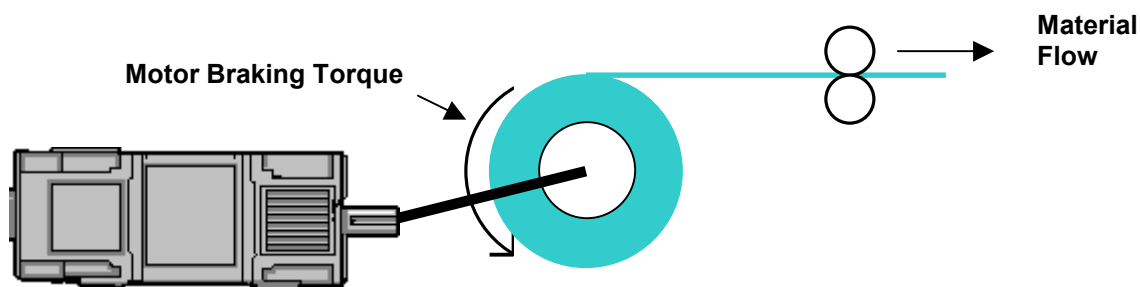

Unwinder

On many unwind stands the braking torque is created through the use of friction brakes and eddy current type brakes. The friction brakes wear out over time (need to be replaced) and need to be re-adjusted as they wear and even heat up. The eddy current brake has better control of the braking torque but is not very energy efficient. The DC motor approach with a Focus 3 regenerative drive provides energy efficient operation since the mechanical braking energy is converted to electrical energy and regenerated back to the power line, plus the braking levels are precisely controlled and more repeatable.

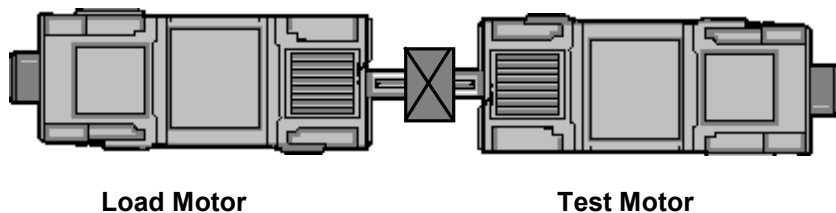

Dynamometer Test Stand

Dynamometer applications in many cases use a water dynamometer to load down a motor for test purposes. These units do not use any electrical energy but do create heat. They also require water supply and drain connections.

In both of these applications, the motor current (torque) needs to be controlled independent of motor speed. Many might think that the drive should be set up as a current regulator, but this is, in most cases the wrong approach. Take the unwind application for instance, when the material runs out, there is no load on the motor. If the drive is set as a current regulator, the drive still “forces” current into the armature causing the motor to accelerate to whatever speed the motor can get to, sometimes as much as twice base speed. This would be a dangerous situation. In the case of the motor dynamometer test stand if the motor being tested trips out (or shuts down for any reason), again the load motor will run away to high speed.

What is the best approach? Set the drive as a speed regulator with a zero speed reference and use the current limit of the drive to control the amount of torque that will be used to enforce the zero speed demand. In this approach, the drive tries to hold zero speed with only as much current (or torque) as the current limit setting will allow. If the external load on the motor decreases or goes to zero the motor will simply stop.

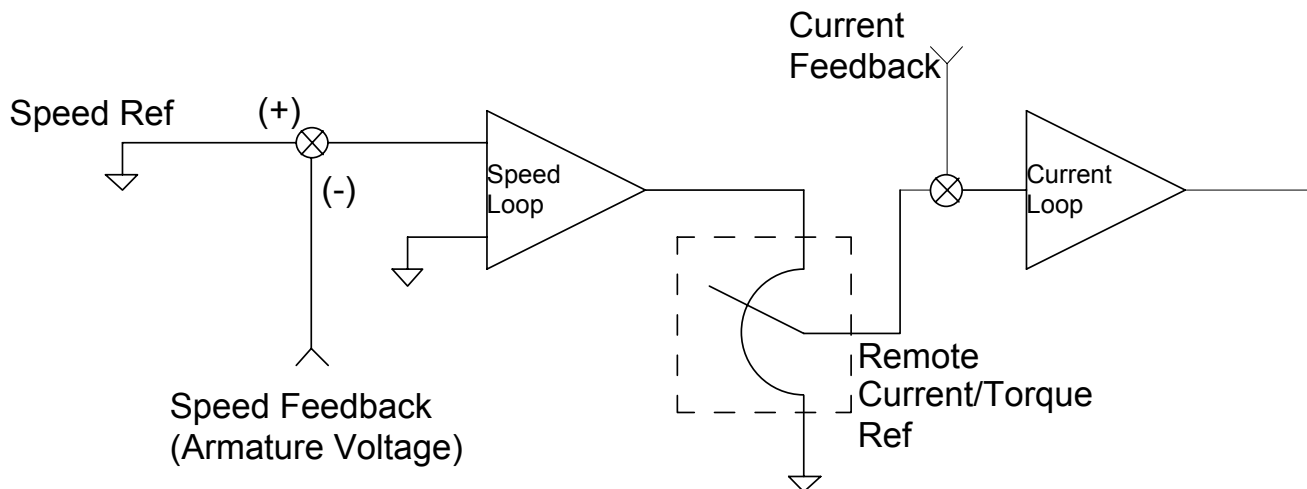

The figure above shows a basic diagram of the drives speed and current loop as configured for the brake control. When speed feedback is zero (motor is at zero speed) the output of the speed loop will be zero and there will be no voltage across the remote current / torque potentiometer. The current reference would be zero and thus command no armature current. When the material starts to pull and cause the motor to turn, the speed feedback signal will start to increase in value causing the output of the speed loop to supply a voltage across the remote current / torque potentiometer. This voltage will then create a current reference based on the setting of the potentiometer causing current to flow into the armature generating braking torque in the motor. Since the pulling force of the material is stronger than the braking torque of the motor, the motor would accelerate to an rpm where the surface speed of the un-winder equals the line speed of the material being pulled off. If for some reason the material breaks or stops pulling, the current in the motor will cause the motor to slow down to zero speed. The speed loop output will go to zero and the motor current will then go to zero. A similar situation as described above occurs in the dynamometer application.

Drive Control Connections

Motor Thermal

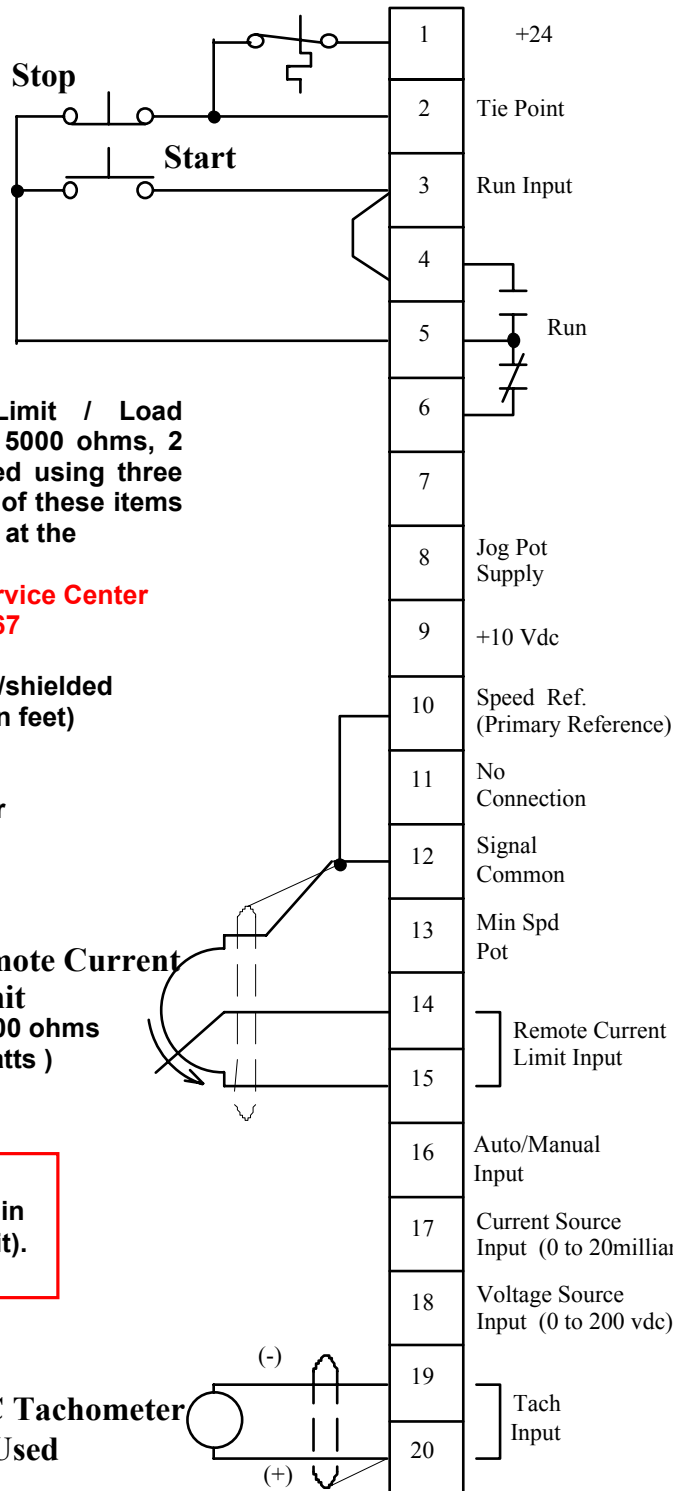

The Remote Current Limit / Load Potentiometer should be 5000 ohms, 2 watts and should be wired using three wire shielded cable. Both of these items are available for purchase at the

Control Techniques Service Center
1-800-367-8067

Three Conductor, twisted /shielded
P/N 3CONcbl-XXX (XXX in feet)

Speed Adjust Pot
3533-0502 – Potentiometer
3549-002 - Knob

Remote Current Limit
(5000 ohms
2 watts)

See page 4 for variations (i.e. min / max torque limit).

Set JP6 and JP7 to Remote (current limit)
****JP9 should be set based on motor full load current**
**** see page 4**

DC Tachometer If Used

Limiting the range of Current/Torque Limit

In many applications, it is desirable to limit the range of adjustment of the remote current limit / torque potentiometer. By placing a resistor in series with the potentiometer, as shown below, this limiting can be achieved. Calculation of the resistor values will be demonstrated in the example below.

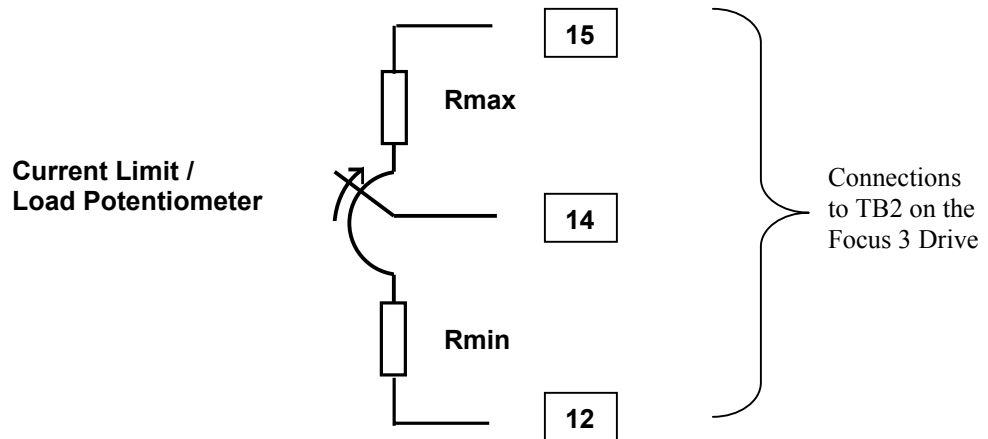

Example:

Suppose you have an Unwinder, as shown below, and the process requires the "hold back" torque to decrease as the roll builds down in order to maintain constant tension. Suppose that at full roll the motor needs 80% current (torque) and since the "build down" is 4:1, the current at core would be 20%. In order to do this, a "lay-on" roll would be required. To make things easy, the gear-in of the potentiometer is such that at full roll the potentiometer is fully clockwise and at min, or empty roll the potentiometer is fully counter clockwise.

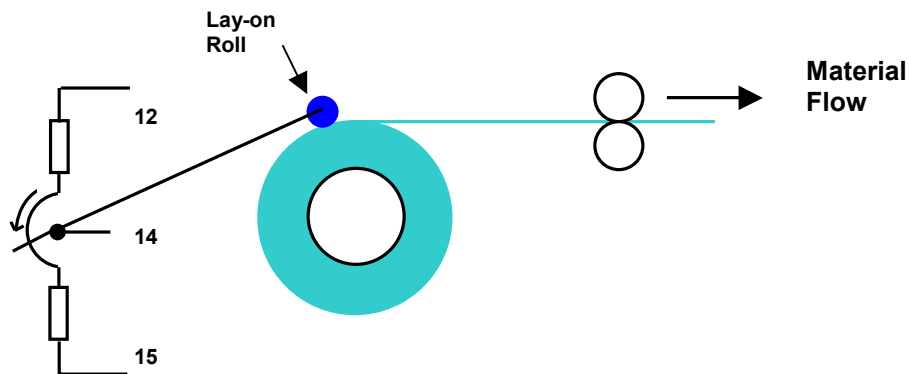

Motor Data: 2HP, 1750 RPM, 180VDC, 10 Amp Armature current.
Drive Data; Focus 3 Regenerative Drive, 2 HP max, P/N F3R2C

The Focus 3 Drive when programmed for 2 Hp at 180 vdc armature is capable of supplying 15 amps (150% armature current) when the current limit is set fully clockwise. The voltage across the current limit pot would be 12vdc (this is the case any time the speed loop is saturated) when the drive was commanding maximum armature current (i.e. speed loop saturated). In this application we need to limit the current to a range of 2 amps to 8 amps. Based on the above, we need to select resistors such that ;

If the current limit pot (connected to the “lay-on” roll) is fully counter clockwise the voltage at the wiper is:

$$V_{min} = \frac{\text{desired current}}{\text{Max current}} \times \text{Voltage at max current demand}$$

$$V_{min} = \frac{2}{15} \times 12 = 1.6 \text{ vdc}$$

If the current limit pot (connected to the “lay-on” roll) is fully clockwise the voltage at the wiper is:

$$V_{max} = \frac{\text{desired current}}{\text{Max current}} \times \text{Voltage at max current demand}$$

$$V_{max} = \frac{8}{15} \times 12 = 6.4 \text{ vdc}$$

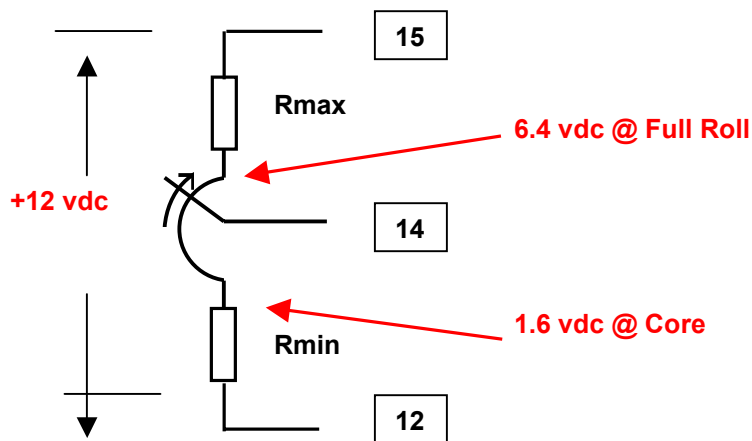

The drawing above shows the voltage levels needed across the lay-on roll potentiometer to achieve proper motor current levels at core and full roll. The values of the resistors, Rmax and Rmin can now be calculated.

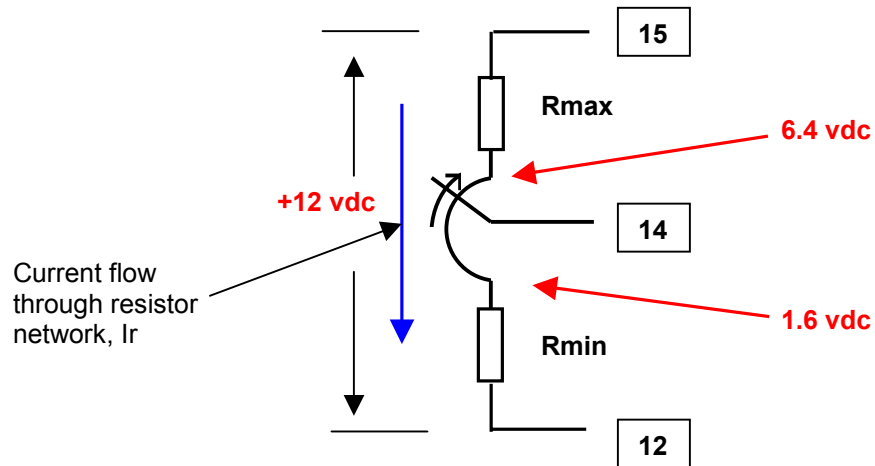

In order to calculate the resistor values, Rmin and Rmax, we need to determine the current flowing through the network. Since we know the voltage drop across the potentiometer and its resistance, the current can easily be calculated.

$$I_r = \frac{\text{Voltage across potentiometer}}{\text{potentiometer resistance}} = \frac{6.4 - 1.6}{5000} = \frac{4.8}{5000} \text{ vdc}$$

$$= 0.96 \text{ milliamps (ma)}$$

Rmin can now be calculated:

$$R_{\min} = \frac{\text{Voltage across } R_{\min}}{\text{Current through } R_{\min}} = \frac{1.6 \text{ vdc}}{0.96 \text{ ma}} = 1666 \text{ ohms}$$

Use 1.6K 5%

Rmax can now be calculated:

$$R_{\max} = \frac{\text{Voltage across } R_{\max}}{\text{Current through } R_{\max}} = \frac{12 - 6.4}{0.96 \text{ ma}} = 5833 \text{ ohms}$$

Use 5.6K 5%

Questions: Ask the author ??

Steve Zaleski Email: <mailto:steve.zaleski@emersonct.com>

Tel: 716-774-1193