

**This Application Note is pertinent for our AC and DC Drive Range**  
Commander GP20, SE, SK, Unidrive Classic, Unidrive SP and Mentor II/Quantum III

## Need another Digital Input ?

No matter how many I/O points a drive may have... when you use them all up and need just 1 more..... well, that can be frustrating. This application note will illustrate how ( when backed against the wall ) one could obtain at least 1 additional digital input and in some cases 2.

### Implementation

Well, as it turns out, most all of our drives have several analog inputs. Often they are unused or there is at least 1 free one. In a pinch, if you need another digital input, you could utilize an un-used analog input for this purpose.

There are some restrictions however. The analog inputs are only rated at 10vdc, so we must not blindly take a +24vdc output signal from a PLC or such directly into this analog input –lest we risk damage to the analog input circuit. *Damage of this sort is detectable during warranty evaluation and would be considered a non-warranty failure.*

However, if the input to be brought to the drive is from a dry contact ( from a relay, pushbutton or selector switch that has no voltage on it ) or from an “Open Collector” output ( transistor output ) then we are good to go. Actually, one could bring in an Analog signal from a PLC that ranged from near 0 to 5 or 10v as well to serve as a digital input signal.

### **Ok, so how do we do it ?**

Well, all of the drives listed in the title above include at least 1 numerical magnitude comparator in menu 12. If we switch the drives +10v reference supply between nothing ( open circuit ) and this +10v supply, the analog input will resolve this as 0 and 100%. We can then pick up this value change and use one of the built-in comparators to turn this into a 0 to 1 bit and then direct it to the control bit of interest ( ie, - the logic bit we want to control with the “digital input” ).

The following descriptions will be centered around our Commander SE series of AC drives however, the principles are essentially identical for our other drive families.

## Using the Voltage Input

For instance, let's take the Commander SE. If we are not using the Analog voltage input (terminal 2) we could use the method being discussed.

Terminal 3 on the Commander SE is +10v. So we would place your input contact or switch between terminal 3 and 2.

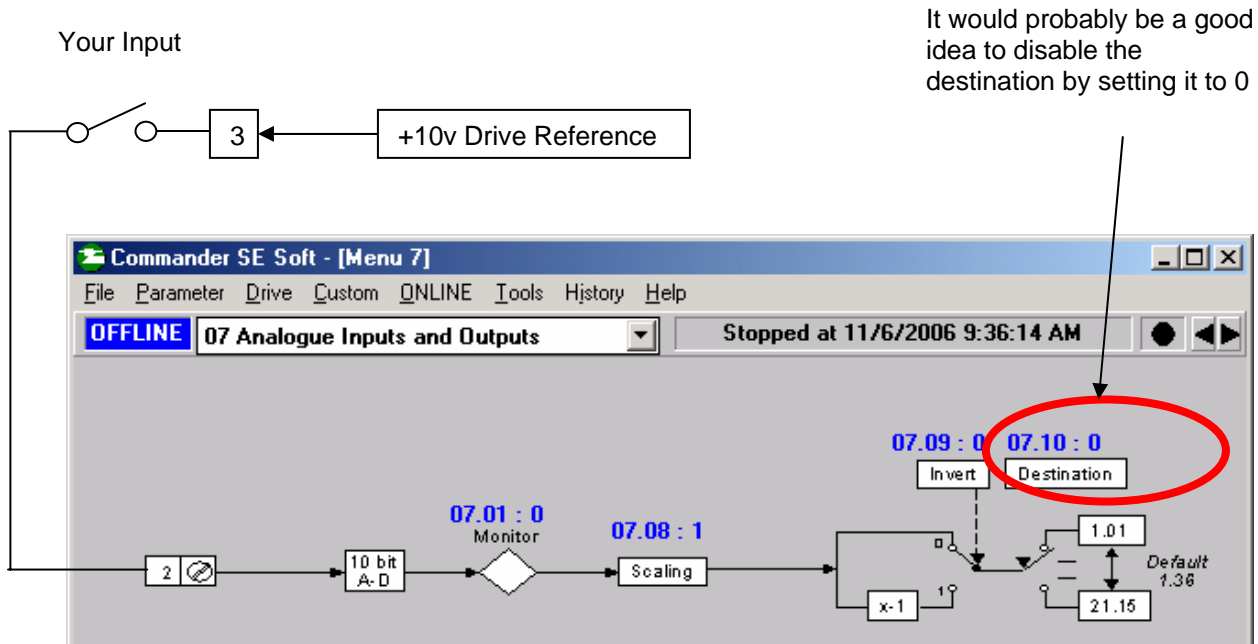

For the next step you would need SEsoft and the CT-Comms serial cable.  
Click here for [SEsoft](#)

You could check to see if your input is working by observing parameter #7.01. It should be about 0.0 when your switch is open and about 100.0 when closed.

Then we would select this signal ( #7.01 ) with our Comparator from Menu 12.

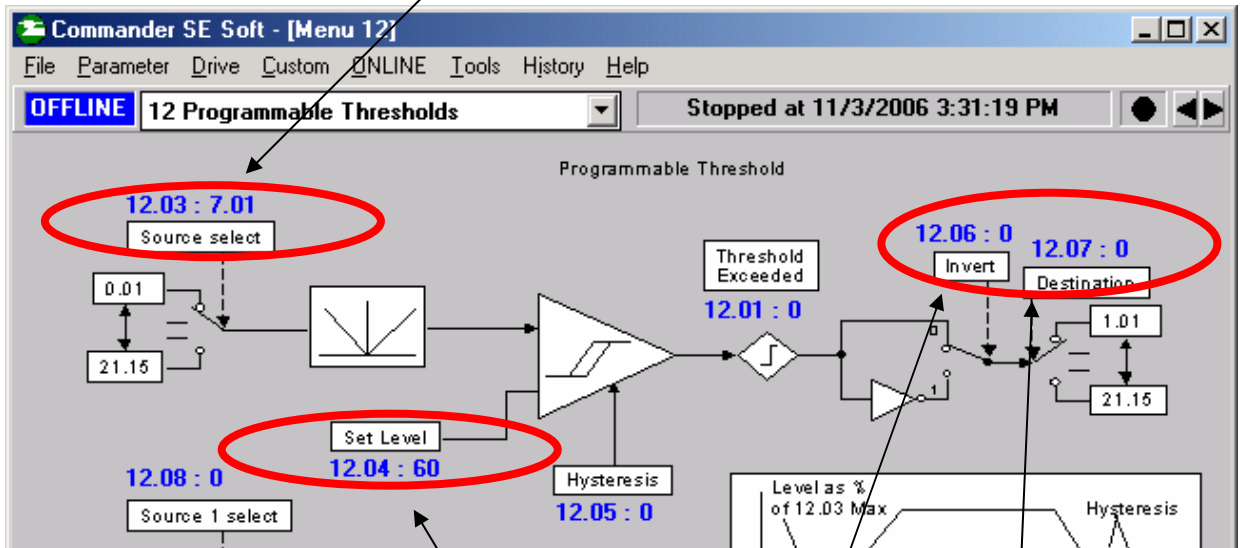

You could set the comparator switch point say around 60% of the voltage swing ( 6v in our case )

Then all you would need to do is to set the Comparator destination ( #12.07 ) to your point of interest that you wish to control. Don't forget to depress the Red Reset button on the drive or use Reset Drive under the Tools pull down menu within SEsoft.

**Note:** If the sense of your input is wrong, #12.06 can be flipped to invert your logic.

## Using the Voltage Input

How about if my signal input originates from an “Open Collector” type of output ?

You would need a pull-up resistor to be installed between the +10v source and the analog input. This resistor could be 5K -10K. The hookup would be as shown below.

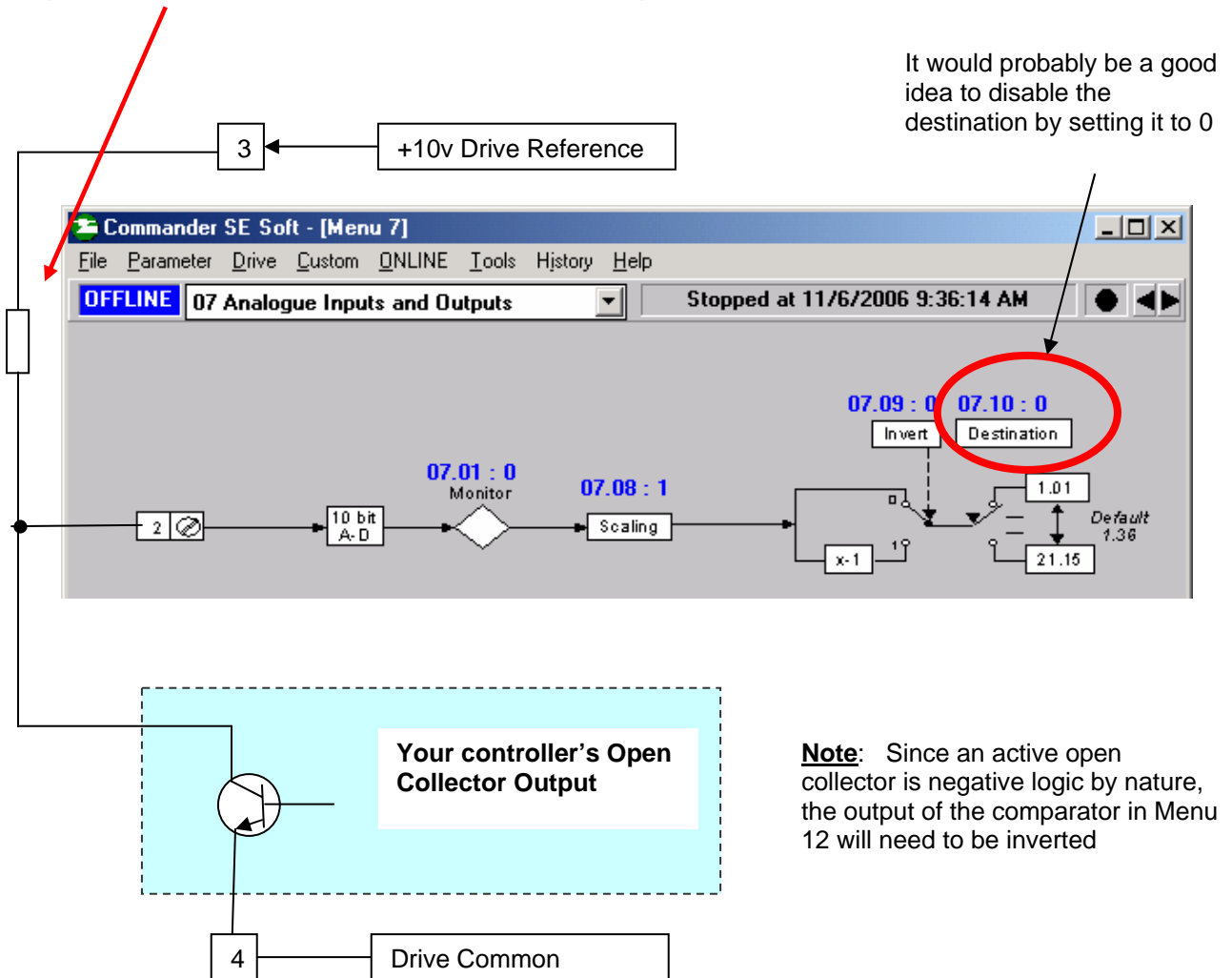

## Using the mA Input

Alright, I understand this but I'm using the analog Voltage input ( terminal 2 ) for the speed control of my drive but the mA analog input ( terminal 5 ) is available. How can I utilize it for another digital input ?

Well basically we can do the same thing except we must take into account that this input must be set up to provide approximately 20mA or zero. We cannot utilize the +10v reference available on terminal 3 as it can only supply 5mA max so we will use the +24v supply available on terminal 7.

So, to limit the input current to 20mA, a resistor must inserted in series with your input contact. By ohms law the value of which should be approximately  $24v/20mA$  or 1.2K So you could use a resistor of 1.2K to 1.5K  $\frac{1}{2}$  watt.

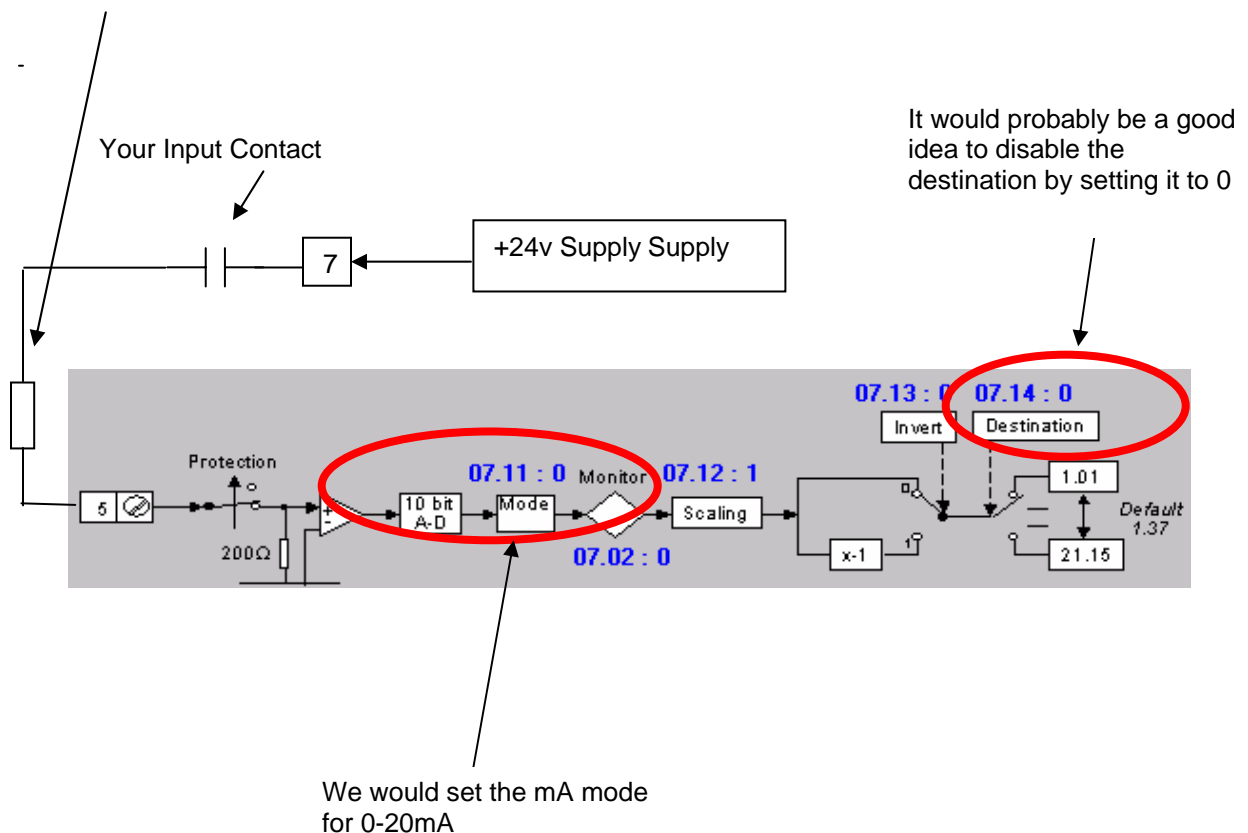

You could check to see if your input is working by observing parameter #7.02. It should be about 0.0 when your switch is open and about 100.0 when closed.

Then we would select this signal ( #7.02) with our Comparator from Menu 12.

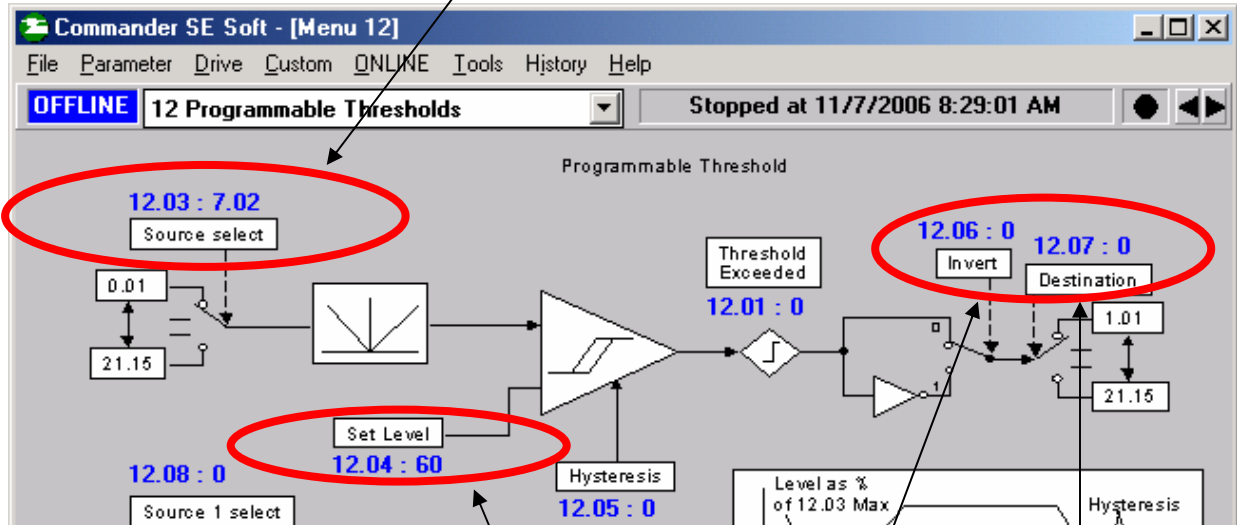

You could set the comparator switch point say around 60% of the voltage swing ( 6v in our case )

Then all you would need to do is to set the Comparator destination ( #12.07 ) to your point of interest that you wish to control. Don't forget to depress the Red Reset button on the drive or use Reset Drive under the Tools pull down menu within SEsoft.

**Note:** If the sense of your input is wrong, #12.06 can be flipped to invert your logic.

## Using the mA Input con't

How about if my signal input originates from an "Open Collector" type of output ?

You would need a pull-up resistor to be installed between the +24v source and the mA analog input. This resistor could be 1.2K -1.5K. The hookup would be as shown below.

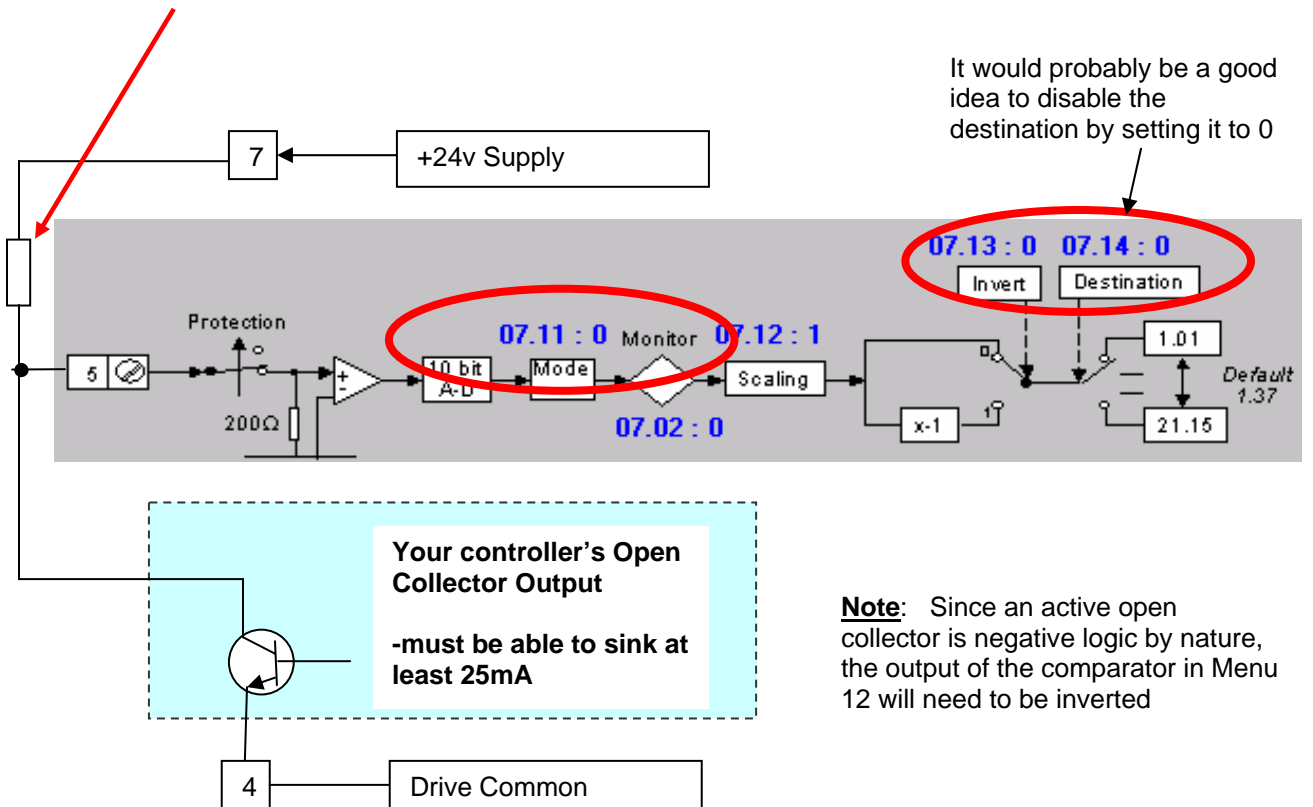

You could check to see if your input is working by observing parameter #7.02. It should be about 0.0 when your switch is open and about 100.0 when closed.

Questions ?? Ask the Author:

**Author:** Ray McGranor  
(716)-774-0093

e-mail : [mailto: ray.mcgranor@emersonct.com](mailto:ray.mcgranor@emersonct.com)