

The Application Note is pertinent to the UnidriveSP, Commander SK, GP20 and Affinity Families

Selecting 1 of 2 Values

On occasion, it becomes necessary to be able to select between 2 values based upon an external contact for instance. For example, let's say you wanted to be able to select one of two current limit amounts. Other applications may include selection between 1 of 2:

- Different Current Limit in Reverse vs Forward
- Gains for different situations
- Selection of 2 different ratios
- Max Speed Scaling to accommodate a different gear ratio
- Current Limit values – an initial hi starting value then a lower running value

This application note will outline a method to select 1 of 2 values by an external contact and there will be examples for various application situations.

Implementation

Note: In all cases cited, the method used takes advantage of the Variable Selectors within Menu 12 of the Unidrive SP. The screenshots in this application note were taken directly from CTSOft which is available free from our website at :

CTSOft

The first 2 modes of the Variable Selectors, modes 0 and 1, perform the function of selecting and passing input 0 or input 1 to its output based on the mode value.

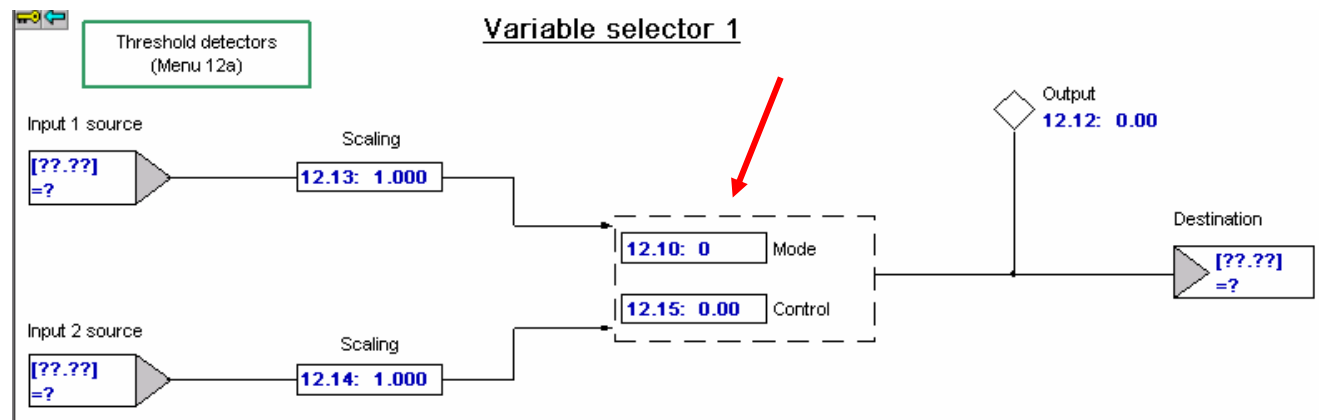

Example 1 Two Current Limit Values

Suppose one wanted to have a reduced current limit of say 50% in Reverse but enjoy say- 165% in Forward. We could use the Running Direction bit, #10.14, to perform this selection if we can get it directed to the mode control bit of the selection Variable Selector. Note that #10.14 will become a 1 when running in reverse.

Parameter	Description	Default	Memory
10.00	Parameter 0	0	0
10.01	Drive healthy	OFF	OFF
10.02	Drive active	OFF	OFF
10.03	Zero speed	OFF	OFF
10.04	Running at or below minimum speed	OFF	OFF
10.05	Below set speed	OFF	OFF
10.06	At speed	OFF	OFF
10.07	Above set speed	OFF	OFF
10.08	Load reached	OFF	OFF
10.09	Drive output is at current limit	OFF	OFF
10.10	Regenerating	OFF	OFF
10.11	Braking IGBT active	OFF	OFF
10.12	Braking resistor alarm	OFF	OFF
10.13	Direction commanded	FWD	FWD
10.14	Direction running	FWD	FWD
10.15	Mains loss	OFF	OFF

Then we can send the result to #4.07 which is an overriding current limit.

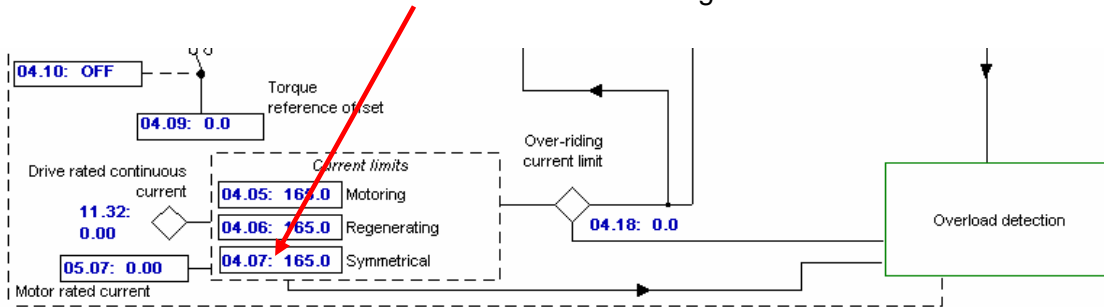

So, somewhat arbitrarily, I decided to place a value of 10000 (about 1/3 of the maximum) into a free parameter #18.11. Then the inputs of a Variable Selector were assigned to #18.11. The output was directed to #4.07. As it turned out, #4.07 was quite close to 50% with a scaler of 1.000 but after the input scaler was adjusted to 0.994, #4.07 was on 50%. Therefore, if 0.994 yields 50% what scale factor would yield 165%.

$$165/50 * 0.994 = 3.28$$

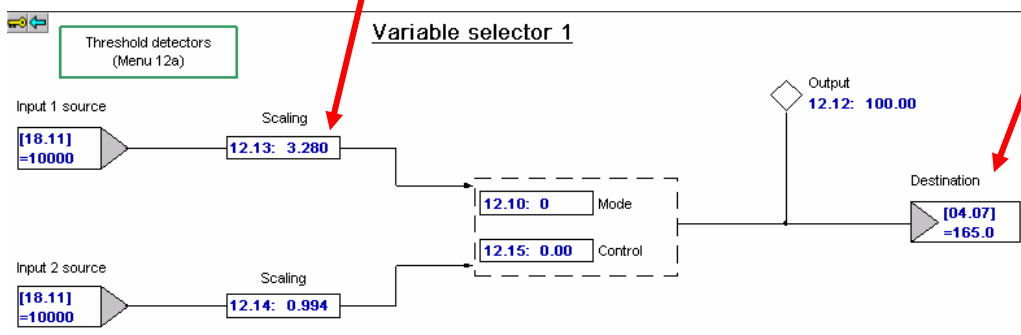

Now, to get #10.14 to control the Variable Selector #12.10 we can utilize the Logic Gates in Menu 9.

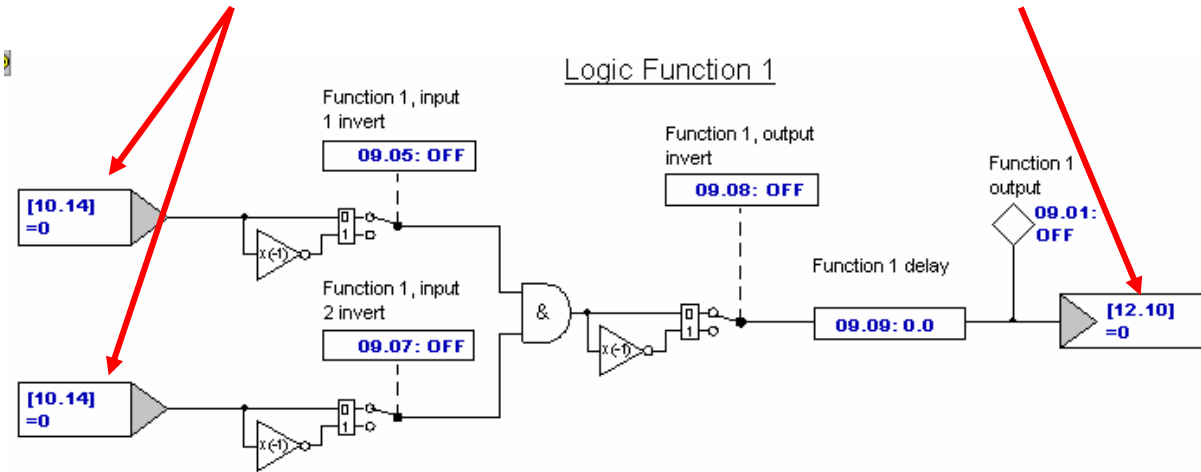

This should do it for the need for a different Current Limit in Reverse vs Forward.

Don't forget to depress the RED reset button to make your assignments take effect.

Example 2 Dual Ratio Selection

To understand the need for such a function it is best to start with an actual example.

Let's take the example of selecting one of 2 ratios. A practical application for such a thing might be in a bakery where they make 2 types of rectangular crackers on the same line but at different times of course. The cracker types have 2 different widths and get broken at the perforation lines from the continuous sheet after the dough is baked. The customer wants to be able to make the machine change from one product to another using a simple selector switch.

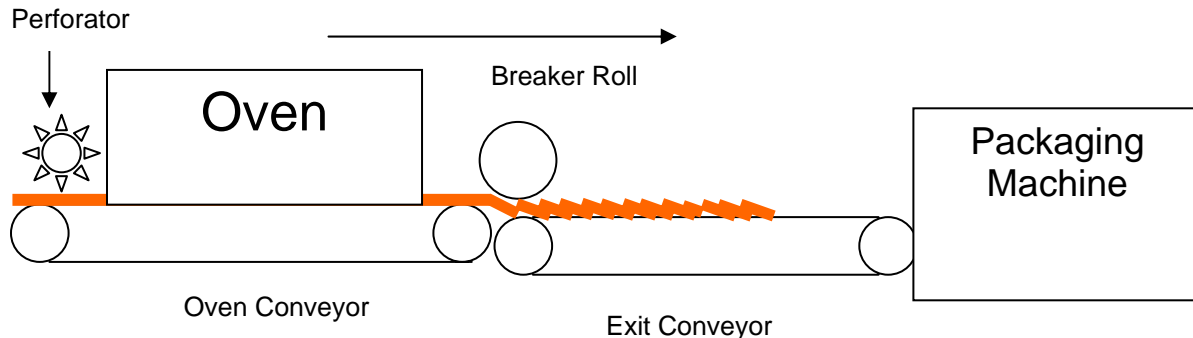

Obviously, the Oven conveyor speed is set as a function of the product baking time based on the material types, Oven temperatures etc. The perforator roll would run at a ratio (preferably digitally locked (a standard built-in function for Unidrive) to the Oven conveyor speed for consistency and ease of packaging. After the product is baked, it is necessary to break the material at the perforation lines to become crackers. For ease of packaging reasons it is sometimes desirable to create an overlap of product. The amount of overlap would again be a ratio to the main Oven Conveyor depending on product type. This is where the dual ratio comes into play for Product A/Product B selection by the Operator.

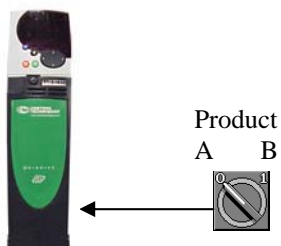

Let's say for this example the two product types require the Exit Conveyor to run at $0.45 \times$ the Oven Conveyors speed for Product A and 0.62 for Product B.

First off all, let's take a quick look at Menu 13, the Digital Locking Menu and specifically the Ratio register parameter #13.07.

Menu 13 Digital Lock Menu

The parameter we wish to change with the Product selection switch is #13.07.

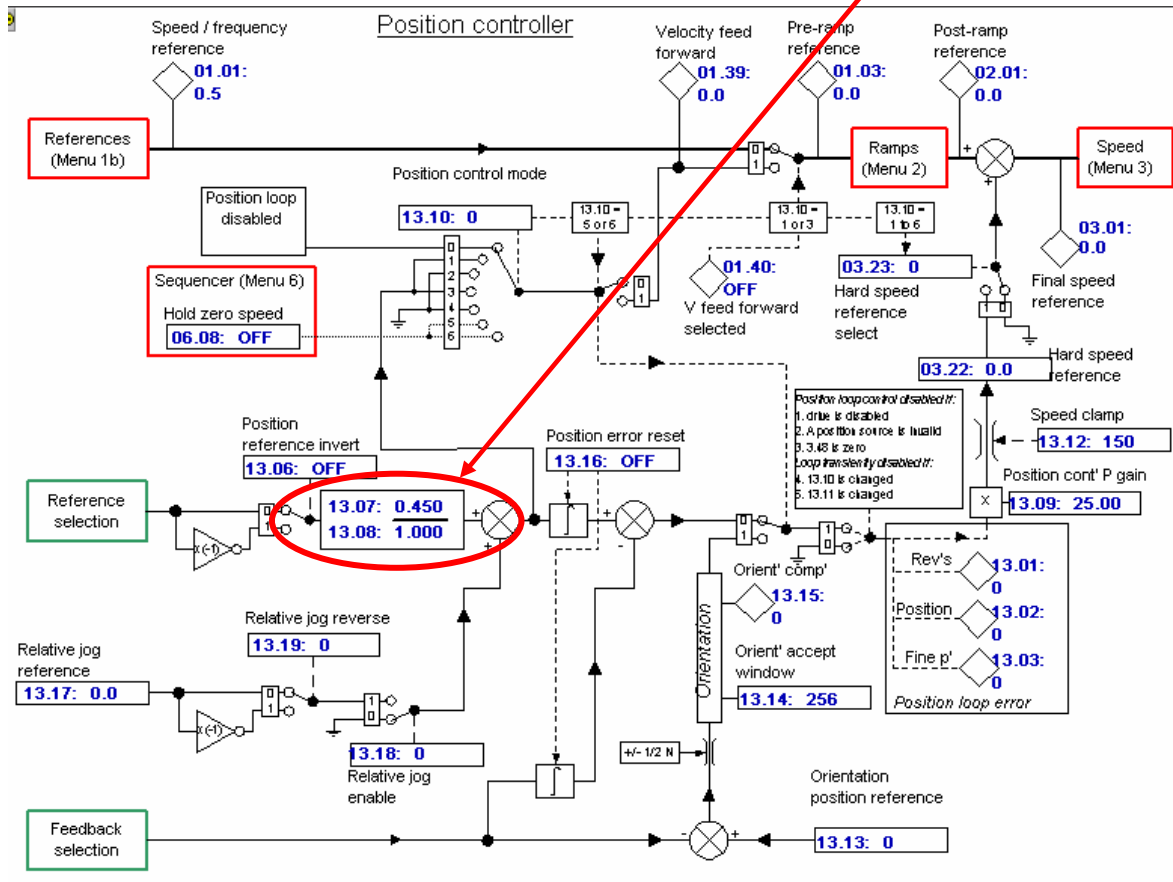

So we can use one of the free Variable Selectors to select between these 2 ratios. If we set the inputs to the Variable selectors to a free parameter –say #18.11. I decided to set up #18.11 to 8192 since this is $\frac{1}{4}$ the maximum value of 32767 therefore $\frac{1}{4}$ of 4.000 or 1.000 that would be sent to #13.07. In this way, then the ratio sent to #13.07 will be whatever is set into the scaling registers #12.13 and #12.14.

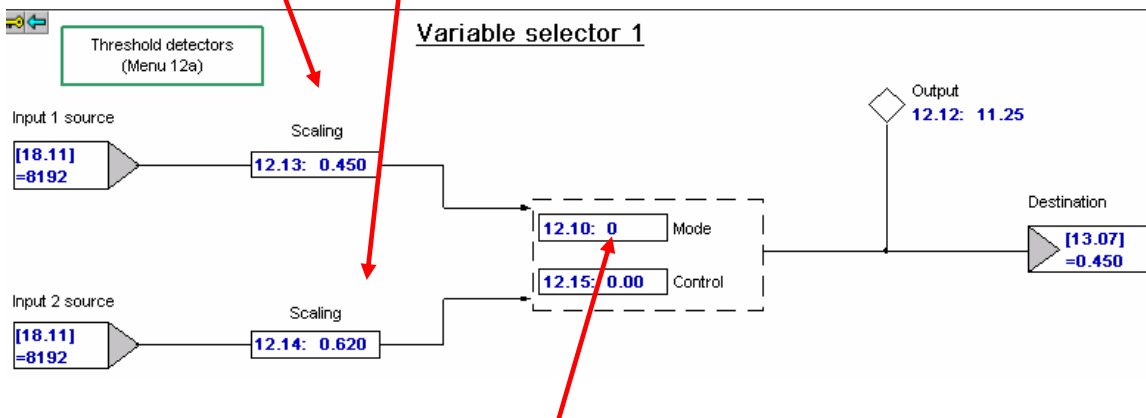

So now all we have to do is to get a digital input to control the mode parameter of the Variable Selector to allow us to select between these adjustable ratios. That's the easy part that I'll leave for you.

Example 3 Hi Starting Torque with Reduction thenceafter

Some applications require a high starting torque for breakaway purposes (breaking loose) but such a torque value during normal running operation could permit damage. For this reason, these applications may need a starting current limit value for a few seconds then a reduced current limit thenceafter. For instance, let's say that a Unidrive model SP1401 is being used to drive a 1.8A motor. For breakaway purposes we may elect to hit the motor with 200% briefly.

Check with the motor and gearbox manufacturer before actually doing so to see what is the maximum torque that the motor shaft and/or gearbox is good for- you don't want to twist a motor shaft or snap a gear tooth !

If we place this motor current into the SP1401 the maximum current limit could be set for as high as **233%** but you feel that you wish to hit the motor with 200% which would provide a high starting torque (*as long as the motor, shaft and gear train can handle it- you must check with motor and overall machine manufacturer*) but may be considered too high for normal running conditions once rolling. Once rolling, you may want to limit the available torque to 125% of the motors rating.

You would set the following parameters on Menu 12.

- #18.11 (just a free location where a driving force can be entered)
- #12.13 = scaled upper current limit (see Current Scaling below)
- #12.14 = scaled lower current limit (see Current Scaling below)
- #12.11 = 4.05 destination of this selection method→ Motoring Current Limit
(4.07 could be used and would limit regenerative torque also)
- #18.11 = 32767 (Driving force) = 100% of Maximum current limit which is found to be 233

Current Limit Scaling

Therefore, if we wanted a starting current of say 200% and a running current limit of 125% we would set :

$$\#12.13 = \frac{200}{233} = 0.858 \quad \text{and} \quad \#12.14 = \frac{125}{233} = 0.536$$

These values may need tweaked slightly to obtain the exact value you desire.

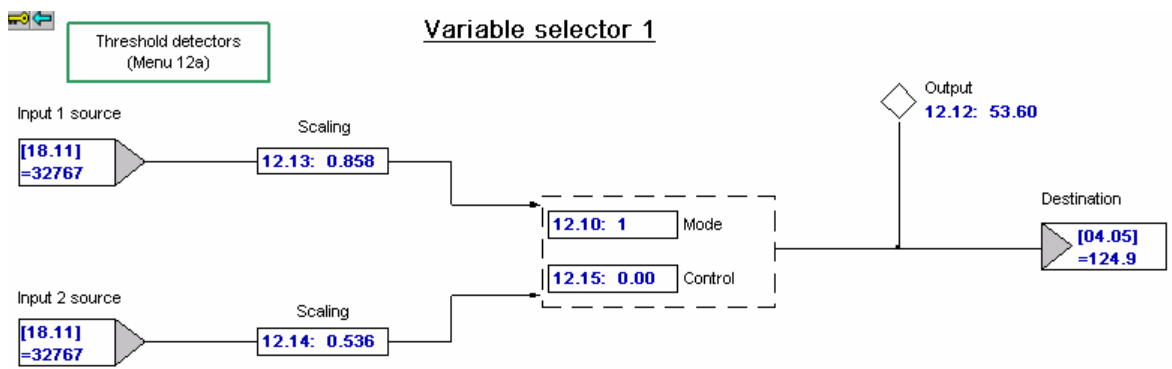

Selection Testing

After entering in the necessary parameters and making the alterations listed above, you are ready to test things. Fortunately, all of this can be tested statically, that is, without running the motor. All you need to do is flip #12.10 from 0 to 1 and observe #4.05 (or #4.07). When #12.10 is 0, the larger of the current limits you desire should appear in that location.

If this works, you are now ready to cause this change to occur automatically upon initial start of the drive and reduce after a delay of your choice. To accomplish this we will use one of the free logic gates of Menu 9 with a programmable output timer.

Parameter	Description	Default	Memory	Units
10.00	Parameter 0	0	0	
10.01	Drive healthy	OFF	On	
10.02	Drive active	OFF	OFF	
10.03	Zero speed	OFF	1	
10.04	Running at or below minimum speed	OFF	OFF	
10.05	Below set speed	OFF	OFF	
10.06	At speed	OFF	OFF	

#10.02 will go to a 1 when the drive is started

The logic functions in Menu 9 have a built-in On-Delay

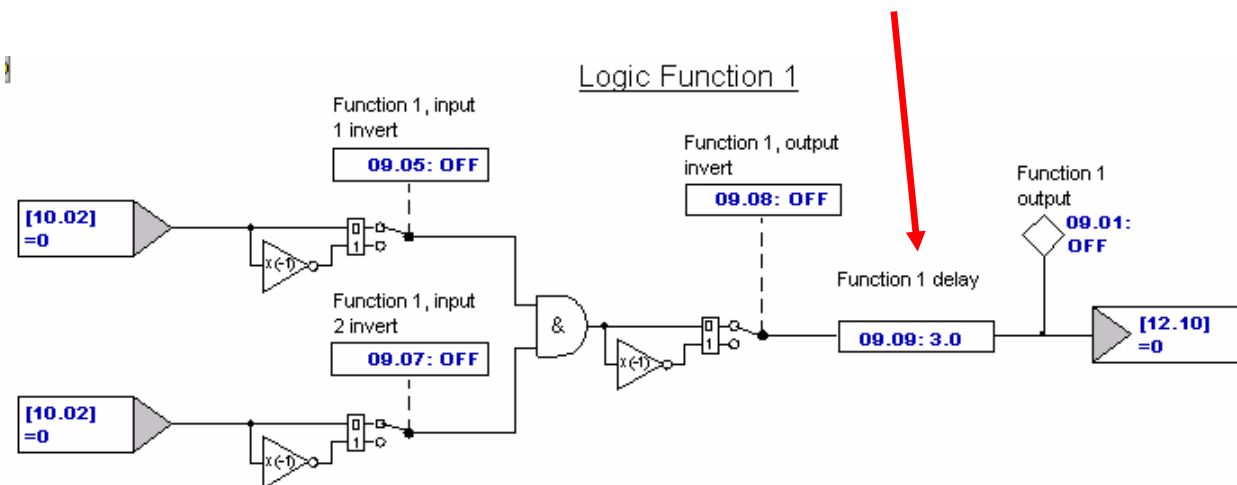

By setting the Drive Active bit into the logic gate inputs #9.04 and #9.06 and setting the Time Delay for my desired duration (for allowing the 200% current upon Start) then directing that resultant output to control the mode parameter of the chosen Variable Selector, our function should be finalized and could now be tested.

Final Testing

In this case you would set the Speed command to 0 and monitor #4.05 or #4.07 based on your earlier decision. Upon Start you should see your 200% then after your short delay setting it should fall back to 125%.

Questions: Ask the author ??

Ray McGranor Email: <mailto:ray.mcgranor@emerson.com>

Tel: 716-774-1193