

4-20mA Current Loop Extensions

This application note is pertinent to the Unidrive SP, Commander GP20 and Affinity Drives

The Unidrive SP , Commander GP20 and Affinity families bring a whole new range of application extension to permit more exotic applications however, as it turns out, there are a few less modes for 4-20mA Current Loop applications that may have been enjoyed by the predecessor drive Unidrive Classic. This application note will examine those mode differences and discuss how to accomplish those potentially useful modes..

The following table below summarizes the various modes of Analog Input #2 and 3 on both the Unidrive Classic compared with Unidrive SP/Commander GP20/Affinity

Analog Input #2,3 Modes (Terminal 7,8)

Unidrive Classic	Modes	Meaning	Unidrive SP	Modes	Meaning
0	VOLt	Voltage input	→ 0	0 -20	0- 20 mA
1	0 -20	0- 20 mA	→ 1	20 - 0	20 – 0 mA
2	20 - 0	20 – 0 mA	→ 2	4-20.tr	4 – 20mA w/Trip on Loss
3	4-20.tr	4 – 20mA w/Trip on Loss	→ 3	20 – 4.tr	20 – 4mA w/ Trip on Loss
4	20 – 4.tr	20 – 4mA w/ Trip on Loss	→ 4	4-20	4 – 20mA no Trip on Loss
5	4-20.Lo	4- 20mA, Min Spd on Loss	5	20-4	20 – 4mA no Trip on Loss
6	20-4.Lo	20- 4mA, Min Spd on Loss	6	VOLt	Voltage Mode
7	4-20.Pr	4- 20mA, Prev Spd on Loss			
8	20-4.Pr	20- 4mA, Prev Spd on Loss			

So in summary, the Unidrive SP/Commander GP20/Affinity does not have the modes that either go to Minimum Speed or stay at the Previous Speed should the 4-20mA signal be lost or fail- Modes 5,6,7, & 8 of the Unidrive Classic. But it is fairly easy to configure the Unidrive SP, Commander GP20 or Affinity drives to provide such features.

Unidrive Classic Mode	Equates to	Unidrive SP Mode	Comment
0	⇒	6	
1	⇒	0	
2	⇒	1	
3	⇒	2	
4	⇒	3	
5	4- 20mA, Min Spd on Loss	Not available	Can be configured
6	20- 4mA, Min Spd on Loss	Not available	Can be configured
7	4- 20mA, Previous Spd on Loss	Not available	Can be configured
8	20- 4mA, Previous Spd on Loss	Not available	Can be configured

Sometimes it is desirable that should a 4-20mA loop signal fail, that the drive continue to run but at some minimum or preset speed or perhaps continue at the same speed. It would also be desirable that should this occur that some form of alert be created as well.

The remainder of this document will outline a method to accomplish Modes 5,6,7 and 8 of the Unidrive Classic for the Unidrive SP, Commander GP20 or Affinity drives as well as a method to annunciate Loop Loss.

The basic 4-20 modes of the Unidrive SP, Commander GP20 or Affinity drives (modes 4 & 5) will not trip on a loss but do provide a indicator bit indicating mA Loop Loss. These indicator bits (namely #7.28 and #7.29) will be used to facilitate creation of these additional modes.

Loop Loss Indication/Annunciation

If one needs an external indication that we have lost the 4-20mA control loop, you need to decide how we tell the world of this. The easiest way perhaps is to turn on a light. So just as an example, we could elect to turn on the Unidrive SP/GP20's relay for this indication. All we would need to do is set the relay source to grab either #7.28 if the mA signal is presented to 7 (or #7.29 if Term 8).

Our Loop Loss indicator light then could be turned on by terminals 41 and 42.

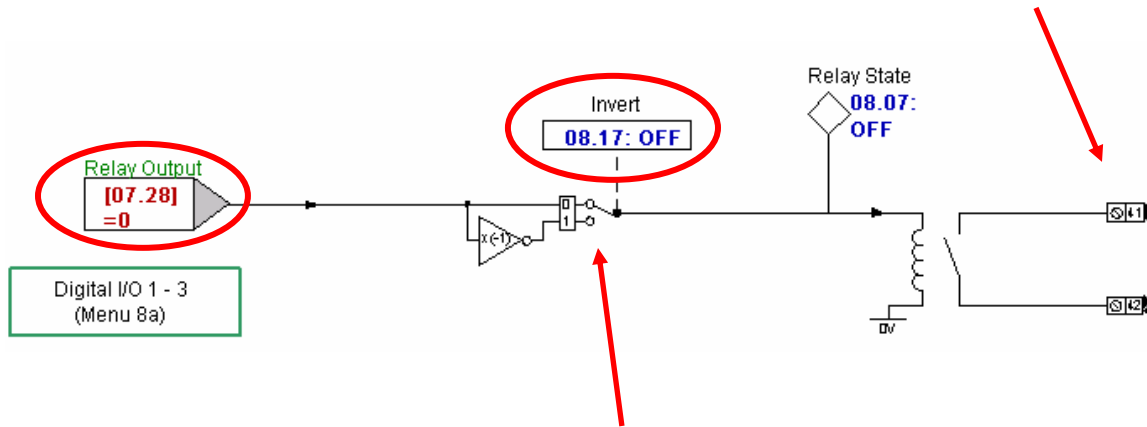

If polarity is incorrect, one could use the inverter to change for the appropriate sense.

See the last page on how to make this Flash a Loop Loss Indicator light !

Implementation Equivalents for Mode 5 or 6

Upon loss of 4-20mA loop

Go to a Minimum or Preset Speed on Loop Loss

Ok, so we have our Loop Loss indication but how do we make the drive go to some speed of our choice if this should occur? Well this is a little more tricky. If we decided to have the drive run at 10% speed upon loss of the 4-20mA input signal and if the drive is set up for a Max Frequency of 60Hz then 10% would be 6Hz. **But how do we get this to occur?** Well there are several ways. The one I have selected is to utilize the rarely used Precision Reference register, #1.18. This reference can be "kicked in" by directing the appropriate mA Loop Loss bit to turn on soft-switch #1.44.

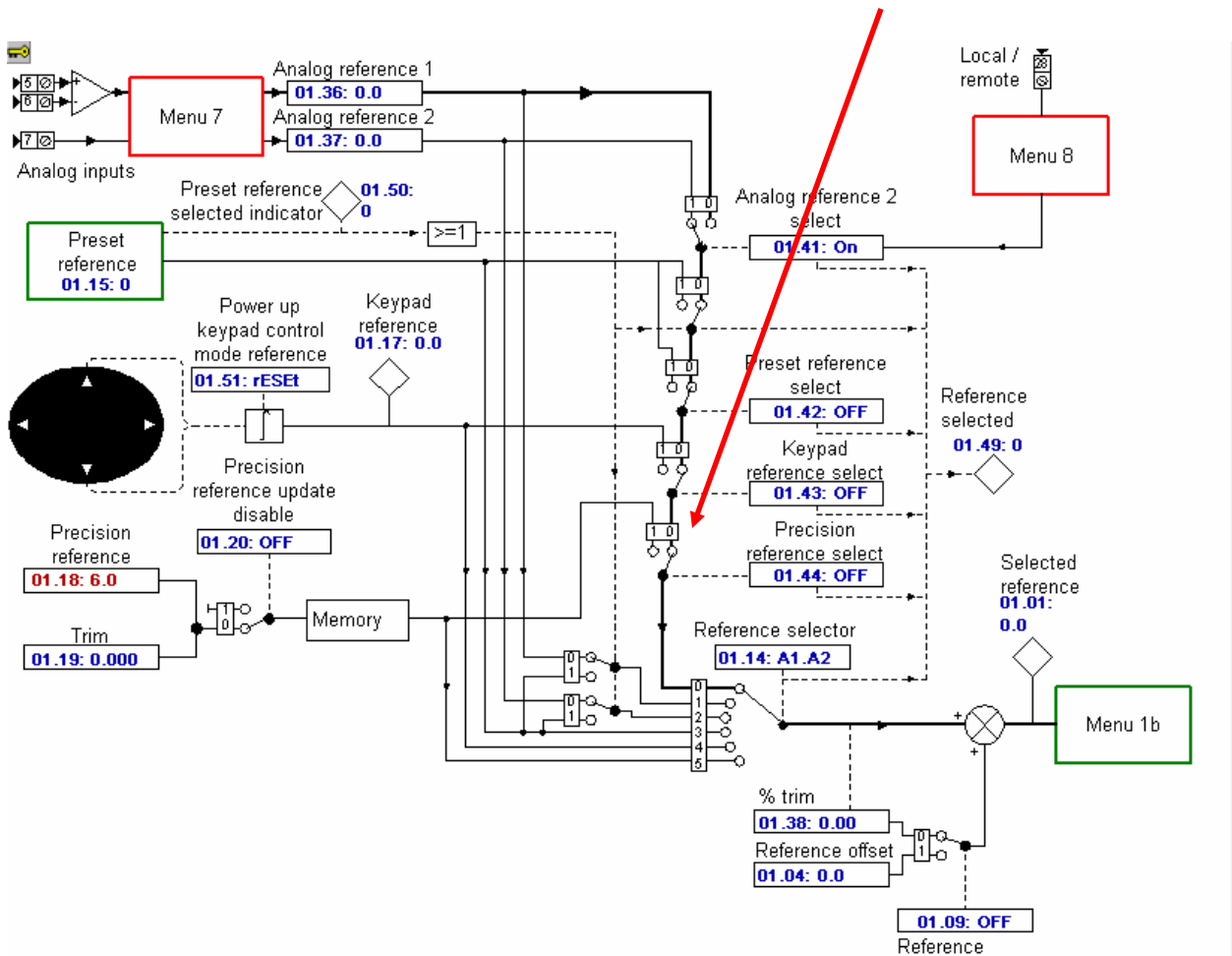

Although there are a few other methods that could be used, I decided to use one of the built-in comparators to redirect the mA Loop Loss bit to control parameter #1.44.

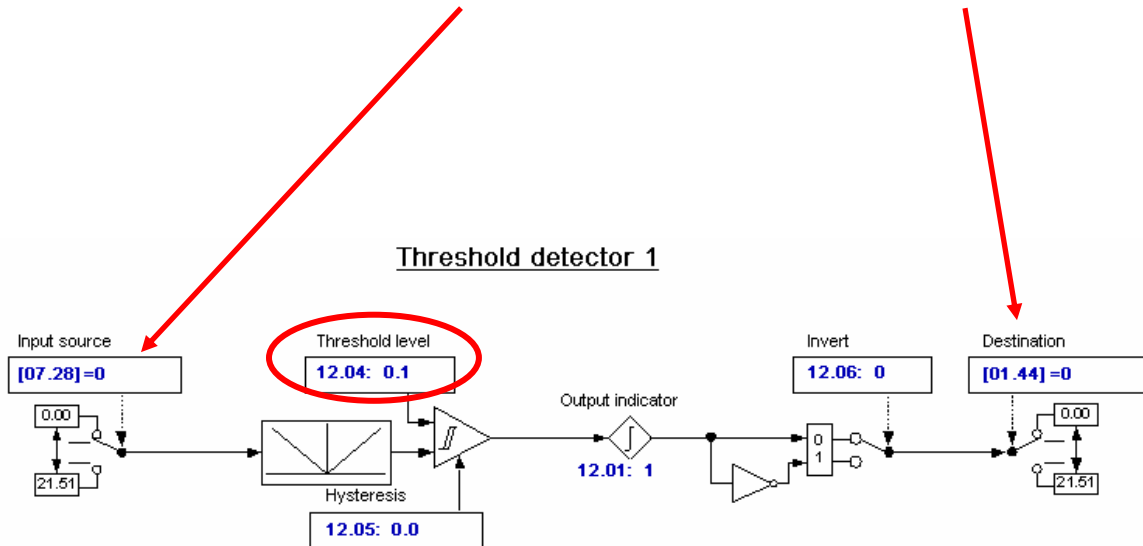

Don't forget to Reset and Store to make all these assignments take effect and remain after a power down.

Implementation Equivalents for Mode 7 or 8

Upon loss of 4-20mA loop, stay at the previous Speed Setting

Actually, this implementation will be essentially the same as for Mode 5 with the exception.... **How do we get the drive to stay at the speed that it was running just before loss of the mA signal ???**

Well, if we can route the Running Speed that was happening just after a mA Loop Loss is detected to #1.18, the drive should continue running at that speed. We can obtain the current running reference from #2.01.

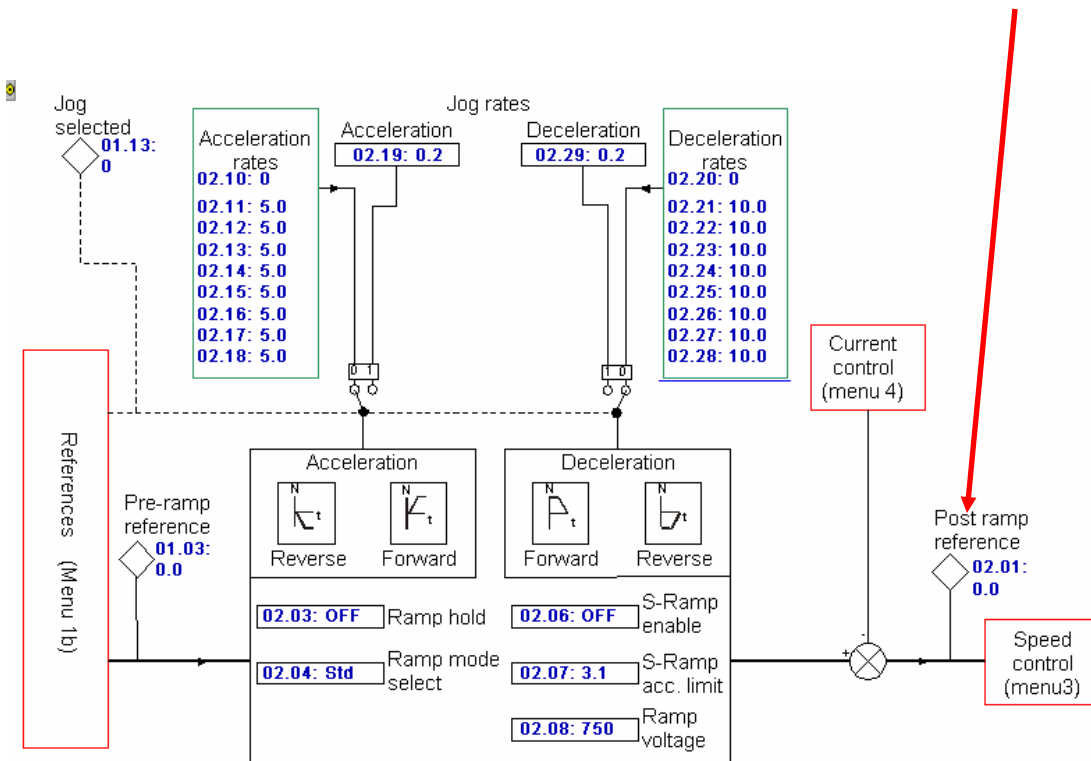

So now for the re-routing

Re-Routing of the Current Speed

We can use one of the variable selectors to re-direct the signal at #2.01 to our selected Reference register #1.18 instead of our Minimum or Preset Speed from the previous example (Mode 5).

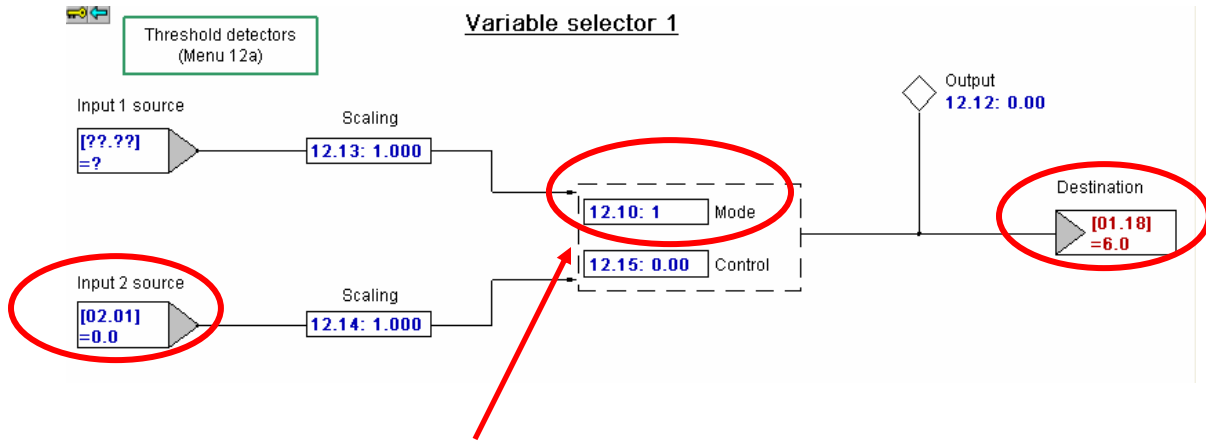

Note: When Mode 1 is selected, Input 2 is passed to the Output of this selector

This should do it !

Don't forget to Reset and Store to make all these assignments take effect and remain after of power down.

Enhancement

If one actually thinks for a moment, they could realize that the last method of using the Variable Selector could be used to combine and solve for Modes 5 and 7. By realizing that when the Mode of the Variable Selector is set to a 1, it passes Input 2 to the Output and when this Mode is set to a 0, it passes Input 1 to the Output. Therefore, we could allow this Variable Selector mode to determine whether we want to maintain the Current Speed or go to a Preset Speed of our choice upon Loss of the mA loop.

But exactly how do we do this ? Well, if we can get Input 1 excited with a value of say 10% (which represents 6Hz) that would satisfy our original criteria for Mode 5- go to a Minimum or Preset Speed .

As it turns out, our Drives have a banks of free, typically un-used registers that can hold values. Menu 18 contains such registers. If we pick on the first available register #18.11 and put a value of 10% of its' maximum, that should do the trick. The maximum value that #18.11 can hold is 32767, so 10% of that would be about 3300. So we will place 3300 into #18.11.

Parameter	Description	Default	Memory	Units
18.00	Parameter 0	0	0	
18.01	Application menu 1 power-down saved i...	0	0	
18.02	Application menu 1 read-only integer	0	0	
18.03	Application menu 1 read-only integer	0	0	
18.04	Application menu 1 read-only integer	0	0	
18.05	Application menu 1 read-only integer	0	0	
18.06	Application menu 1 read-only integer	0	0	
18.07	Application menu 1 read-only integer	0	0	
18.08	Application menu 1 read-only integer	0	0	
18.09	Application menu 1 read-only integer	0	0	
18.10	Application menu 1 read-only integer	0	0	
18.11	Application menu 1 read-write integer	0	3300	
18.12	Application menu 1 read-write integer	0	0	
18.13	Application menu 1 read-write integer	0	0	
18.14	Application menu 1 read-write integer	0	0	
18.15	Application menu 1 read-write integer	0	0	
18.16	Application menu 1 read-write integer	0	0	
18.17	Application menu 1 read-write integer	0	0	
18.18	Application menu 1 read-write integer	0	0	

So all we need to do is assign Input #1 to look at #18.11.

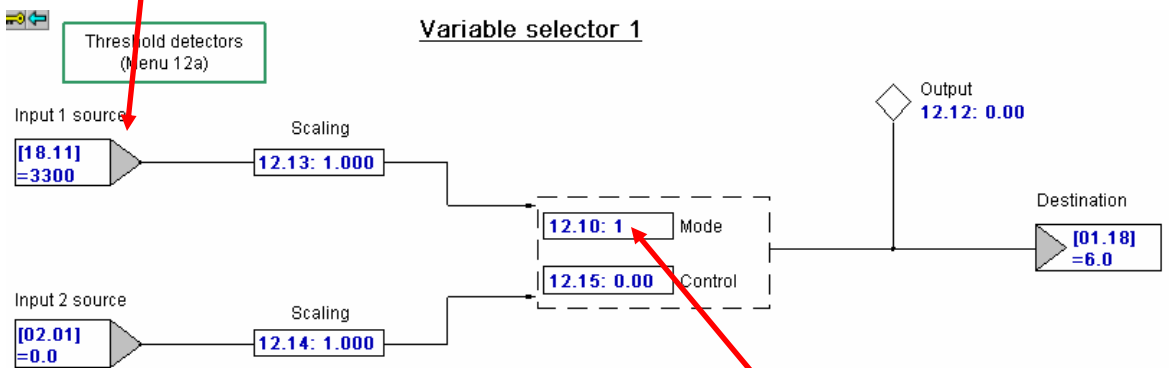

This will determine whether we stay at the Previous Speed or Go to a Preset Speed upon Loop Loss
 0= Your Preset Lo Speed 1= Previous Speed

Summary

So to summarize, in order to achieve the equivalent modes 5, 6, 7 and 8 of the Unidrive Classic, one can implement them fairly easily with the programmable functions lying about within the Unidrive SP/GP20.

Analog Input #2 (Terminal 7) Mode Extensions

Unidrive Classic Mode	Mode Description	Unidrive SP/GP20 Parameter Setup
5	4- 20mA with Min Speed on Signal Loss	#7.11 = 4-20 #12.03 = 7.28 #12.04= 0.1 #12.07 = 1.44 #12.08=18.11 #12.09=2.01 #12.10=0 #12.11=1.18 #18.11= 3300 for 10% speed
6	20- 4mA with Min Speed on Signal Loss	#7.11 = 20-4 #12.03 = 7.28 #12.04= 0.1 #12.07 = 1.44 #12.08=18.11 #12.09=2.01 #12.10=0 #12.11=1.18 #18.11= 3300 for 10% speed
7	4- 20mA and stay at Previous Speed on Loss	#7.11 = 4-20 #12.08=18.11 #12.09=2.01 #12.10=1 #12.11=1.18
8	20- 4mA and stay at Previous Speed on Loss	#7.11 = 20-4 #12.08=18.11 #12.09=2.01 #12.10=1 #12.11=1.18

Don't forget to Reset and Store to make all these assignments take effect and remain after of power down.

Analog Input #3 (Terminal 8) Mode Extensions

Unidrive Classic Mode	Mode Description	Unidrive SP/GP20 Parameter Setup
5	4- 20mA with Min Speed on Signal Loss	#7.15 = 4-20 #12.03 = 7.29 #12.04= 0.1 #12.07 = 1.44 #12.08=18.11 #12.09=2.01 #12.10=0 #12.11=1.18 #18.11= 3300 for 10% speed
6	20- 4mA with Min Speed on Signal Loss	#7.15 = 20-4 #12.03 = 7.29 #12.04= 0.1 #12.07 = 1.44 #12.08=18.11 #12.09=2.01 #12.10=0 #12.11=1.18 #18.11= 3300 for 10% speed
7	4- 20mA and stay at Previous Speed on Loss	#7.15 = 4-20 #12.08=18.11 #12.09=2.01 #12.10=1 #12.11=1.18
8	20- 4mA and stay at Previous Speed on Loss	#7.15 = 20-4 #12.08=18.11 #12.09=2.01 #12.10=1 #12.11=1.18

Don't forget to Reset and Store to make all these assignments take effect and remain after of power down.

One Last Embellishment

Alright ! It looks like we have our methods to handle 4-20mA loss of signals but one last thing perhaps. How do we let the Operator know that the 4-20mA loop has failed ? Modes 3 & 4 will simply trip the drive and everyone will know something happened. But with these new modes, the drive will continue running either at a low speed or at the previous speed- so we may need to tell someone this has occurred in some manner.

Obviously, we could just turn on a relay output to light a light but there is no denying that a blinking light will get more attention. This next portion will outline how to setup the drive to create a flashing light when the 4-20mA loop has failed.

Flasher Quick Setup Table

These summary tables will allow you to quickly configure either a Unidrive SP or GP20 by simply programming locations directly from that table to achieve the flasher function.

For a more complete description of what this table is doing, consult [CTAN201](#).

Unidrive Classic, Unidrive SP or GP20

Parameter	Setting	Comment	
#9.04	7.28 or 7.29	Your selected output	Loop Loss
#9.05	0 or OFF		
#9.06	9.01	Feedback from output	
#9.07	1 or ON	Invert this input	
#9.08	0 or OFF		
#9.09	1.0	1 second overall period	Adjustable
#9.14	9.01	Input from Gate 1 Output	
#9.15	1 or ON	Invert this input	
#9.16	9.01	Input from Gate 1 Output	
#9.17	1 or ON	Invert this input	
#9.18	0 or OFF		
#9.19	0.5	0.5 seconds	Adjustable
Relay Output			Term 41-42
#8.27	9.02	Output of Gate 2-Flasher	
#8.17	0 or 1	Invert if necessary	

Normally you would set #9.19 to ½ of #9.09. Parameter #9.09 must be greater than #9.19.

Parameter #9.09 must not be equal to #9.19 for proper operation.

Don't forget to Reset and Store to make all these assignments take effect and remain after of power down.

Questions ?? Ask the Author:

Author: Ray McGranor
(716)-774-0093

e-mail : ray.mcgranor@emersonct.com