

The Application Note is pertinent to the  
Commander SK, Commander GP20 and Unidrive SP Drive Families

## Line Speed plus Trim

A common drive application involves following a Process Line Speed but needing a trim. This application note will address such a function and describe how to accomplish it using inherent features within the Commander SK, Commander GP20 and Unidrive SP Drive Families. This application note will outline how to achieve this function using the Commander SK but the method is almost identical when using the Commander GP20 or Unidrive SP.

Consider the application below. The application involves a product being pulled perhaps from a roll by a Master drive ( Unidrive SP which is running a Vector motor). The downstream follower drive ( being a Commander SK running a common induction motor), is to run at an adjustable speed proportional to the Master drive. There may be an exit Pull Roll which may be running in Digital Lock with the Entry Pull Roll but that's the topic for yet another Application Note.

Depending on the amount of overspeed ( or underspeed ) of the Finishing Rolls, different types of surface textures or finishes can be achieved. Some applications may require a +10% or more overspeed and yet other products may require a -10% relative speed for just the right surface finish.

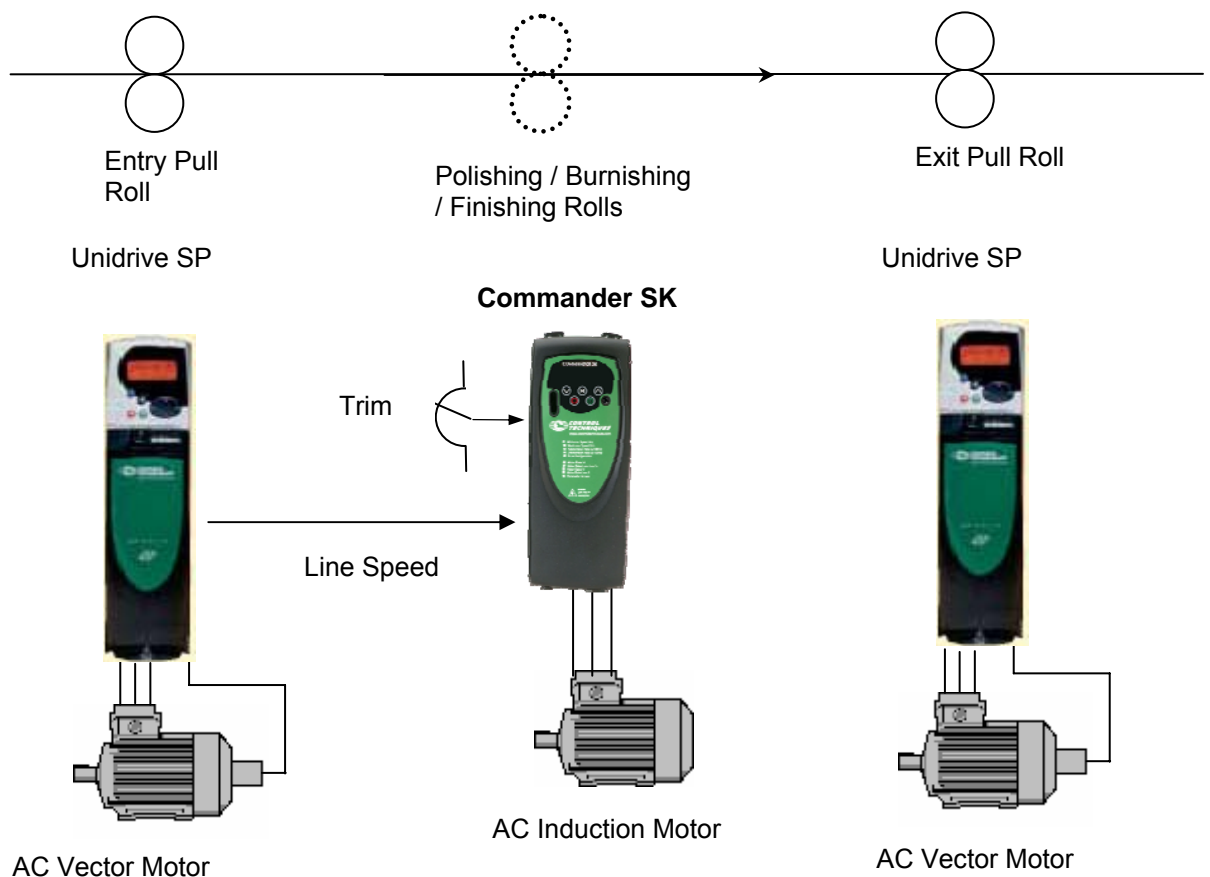

## Can the Commander SK be configured to achieve this kind of application ?

Sure. In fact there is a built-in feature in Menu 1 for this very application.

### But how do we do it ?

Well, it will involve the use of CTSofT ( Drive configuration software available for free from our website at [www.controltechniques/ctsoft](http://www.controltechniques/ctsoft) or click -> **CTSoft** ).

The Commander SK has 2 analog inputs available. One of which we will use to bring in the LINE SPEED signal ( to terminal T2 ) to be followed. The other will be used to bring in an Operator adjustable TRIM pot via terminal T4.

We could bring in the Line Speed signal as a 0 to +10v signal from the Master Drive. The analog input on T2 on the Commander SK is configured as a mA current signal input by default. Actually leaving it as a mA input can have the advantage of offering superior noise immunity characteristics. It can be configured for a variety of common modes 4-20mA, 0-20mA etc. For our example, we are taking advantage of the Master UnidriveSP to output its' values as a 4-20mA signal and we can configure the SK to trip on a 4-20mA loss or loss of the Master Reference signal- which may be a desirable characteristic.

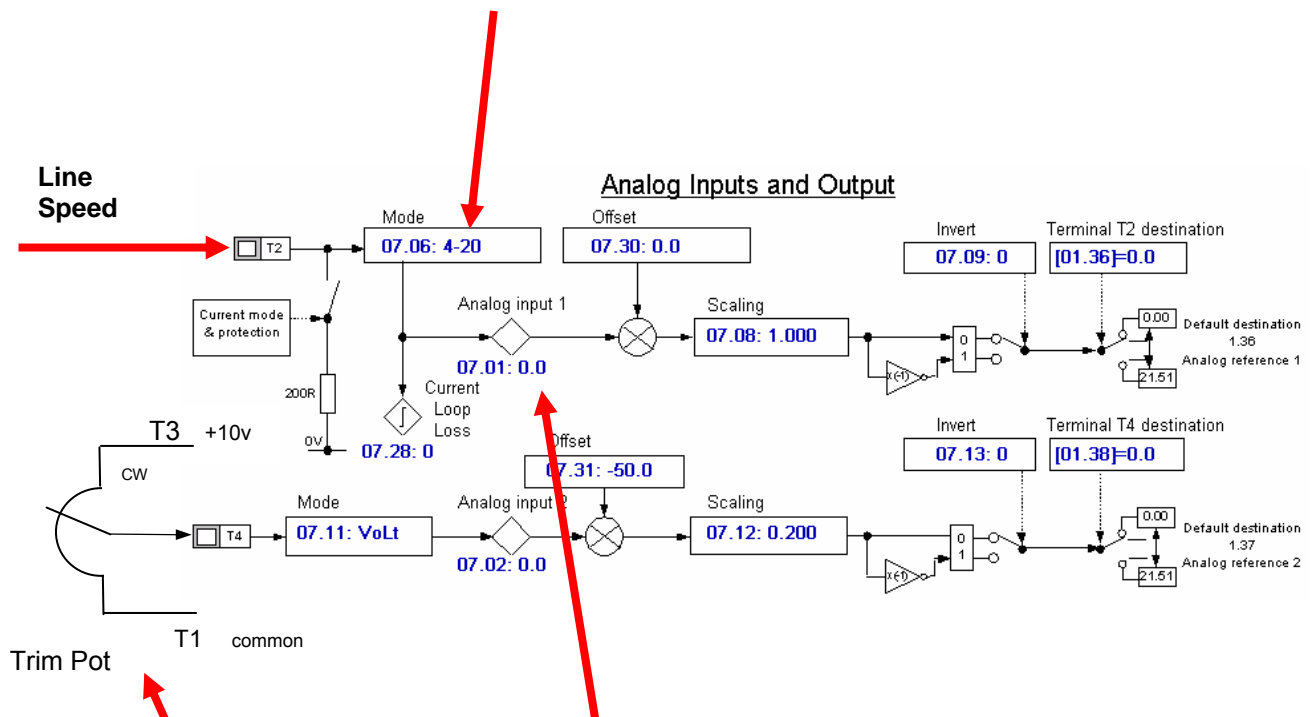

The percentage of input Line Speed can be monitored at parameter #7.01.

The Trim pot shown above can be 5K $\Omega$  or 10K $\Omega$  ( Linear Taper )

## Trim Signal

One must ask, “ **Does the Trim need to be unipolar or bi-polar ?** ( ie +/-xx% or only 0 to +XX% ).

For this example, I have selected a bi-polar trim of +/-10%. Normally, to achieve this, one would merely connect one end of the trim pot to a + reference supply and the other to a – reference supply. The Commander SK has only a + reference supply. But this is no problem, we can simply use the built-in offset to bias the incoming TRIM so that both + and – trim can be achieved.

Since the trim input provides us with a 0 to 100% signal on #7.02, we can bias it with a constant -50% value so that when the pot is at full CCW it will result in –50% and at full CW yield +50% . Unfortunately the result of the offset cannot be directly read but in can be inferred by looking at the resulting value in the destination parameter register.

Now as far as the scaling for +/-10%, this can be accomplished using the scaling multiplier after the offset. With a scaler of 1.000, we would have +/-50% therefore if we want +/-10% we need 1/5<sup>th</sup> of that so we would set the scaler to 0.200.

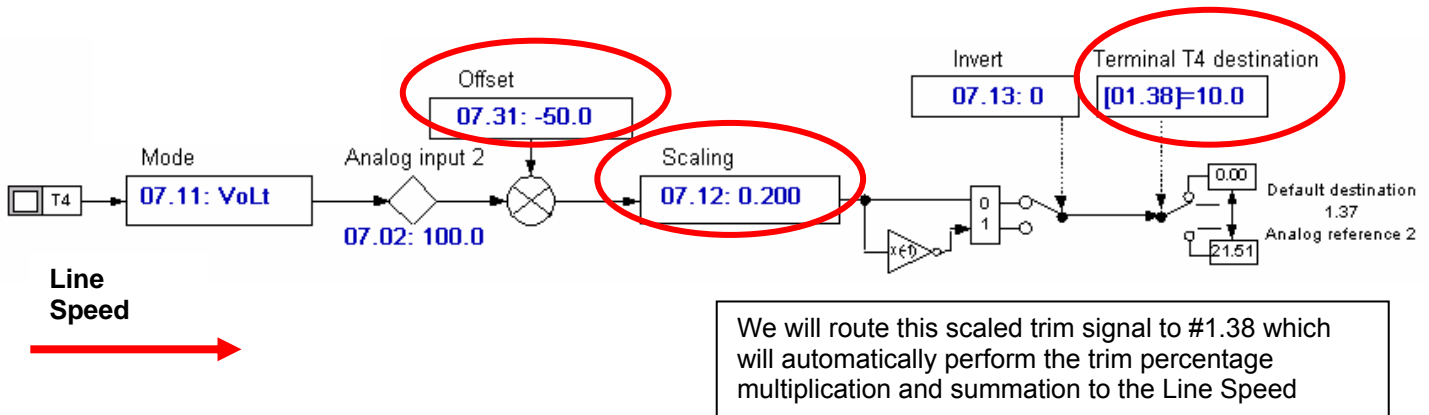

The destination of the trim is set to #1.38.

Don't forget to depress the Red Stop button or Reset Drive via CTSof for the destination assignment to take effect.

## Uni-Polar Trim Signal

If we had desired only 0 to 10% trim, one would merely leave the offset ( #7.31) at 0.00 and adjust the scaling multiplier to 0.1.

## Line Speed + %Trim

To achieve this function we can use one of the standard features available within the drive. Menu 1 within the drive contains an automatic percent trim summing function. On the Commander SK it is parameter #1.38.

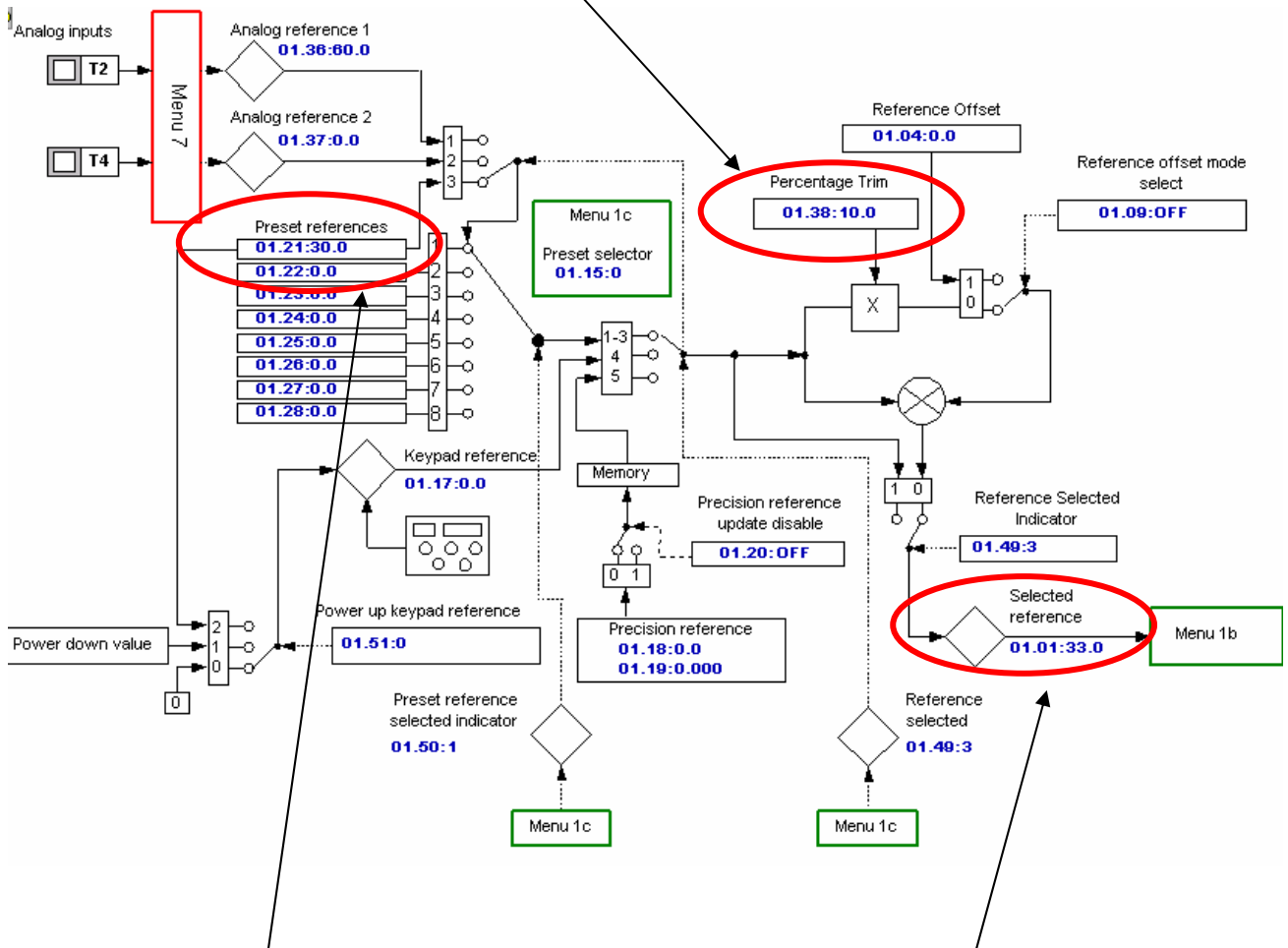

Prior to taking the screenshot above, I turned the Trim pot to maximum which resulted in a +10% Trim into #1.38 above. Since I did not have a Master connected and did not have access to a 4-20mA source, I temporarily set the drive up to follow Preset Speeds by setting parameter #0.05= Pr. I set #0.18 ( which is Preset #1 ) to 30Hz.

Also notice that the resultant speed demand from the 30Hz preset has become 33Hz as dictated by the 10% trim adder.

***It should also be noted that we did this without running the drive !!***

This is always the case. You should always try to simulate your conditions and check for proper function before attempting to run the motor !

**So this is it ???** Well not quite. There is a problem.

Observe Menu 1 and specifically #1.38 and #1.01 to see how your trim is working. What you may notice is that the trim works fine but won't trim above your drives maximum frequency setting ( parameter 0.02 or #1.06 ). For instance, if your Max Frequency is set for 60Hz, +10% trim will only work up to around 54 Hz since  $54 \times 1.1 = 59.4\text{Hz}$  then any additional trim request is clamped. In fact, it tends to max out when we set the Preset Speed to 54.6Hz.

Ahhh yes - mathematics !!!  $54.6 + 10\% = 54.6 + 5.46 = 59.96$   
and when rounded becomes 60.0

Since we have either set or left the drives Max Frequency at 60Hz ( parameter #0.02 ), the drive will enforce this limit.

At this point we would have to ask ourselves, **"Is it ok that the drive being trimmed tops out at 60Hz ?"** or **"Could it be allowed to go to 60Hz + 10% or 66Hz ?"** On a standard 4pole 1800rpm motor this would mean that the motor would have to go to  $1800 + 10\%$  or  $1800 + 180 = 1980\text{rpm}$ .

**If this speed is ok, then how would we achieve this ???**

**What happens if we just set the Max Frequency ( parameter #0.02 ) to 66Hz ?**

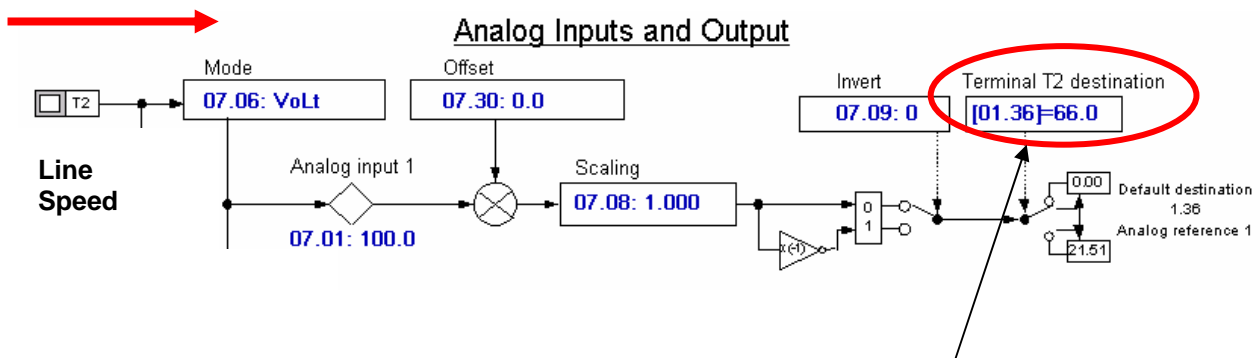

Well if we set the Maximum Frequency to 66Hz, full Line Speed Input would yield 66Hz at #1.36. Analog signals are automatically scaled to the Maximum Frequency setting. Therefore with +10% trim this  $66 + 6.6$  would become a total of 72.6Hz but the drive will limit anything above 66 Hz. So this by itself will not work !!!

We would need to re-scale the analog Line Speed input so that it represents only 60Hz so that the Percent Trim of +10% would yield 6Hz + 60. We would set the scaling multiplier  $60/66 = 0.910$  to:

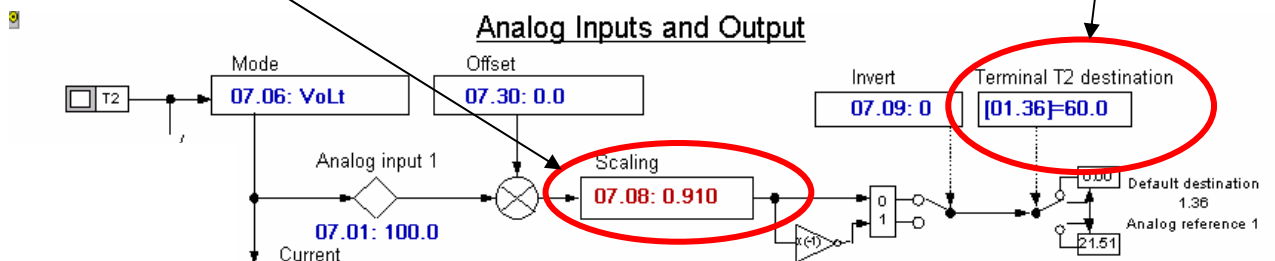

# Analog Trim Summary

So this should do it !.

With +10% trim we see #1.01= 66Hz and with -10% trim we see 54Hz.

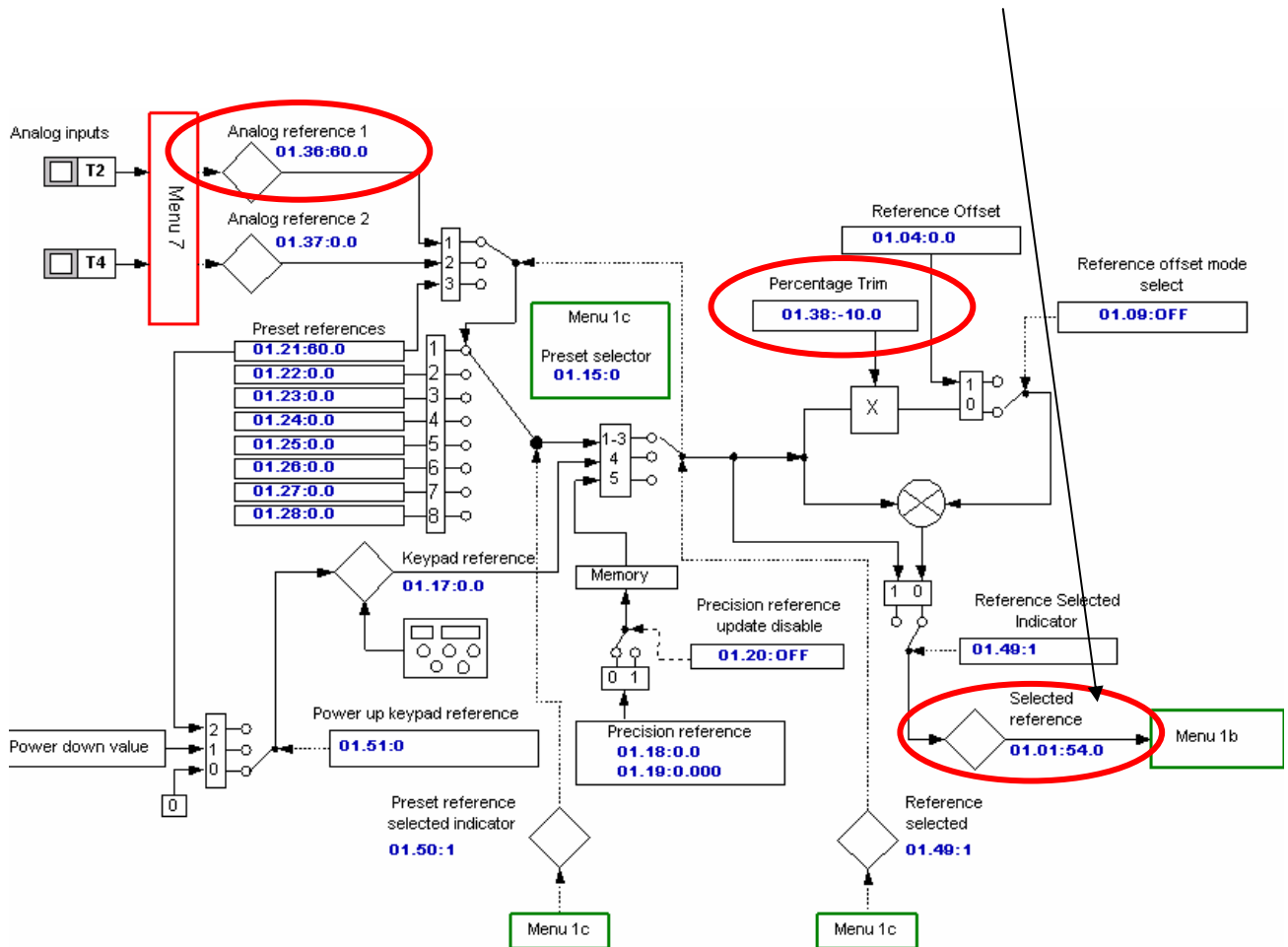

## %Trim vs Fixed Amount

The previous example used %Trim which is common for many types of applications. Parameter #1.38 provides a convenient method of summing in this trim percentage with the applied reference. Other times instead of %Trim, applications may require a fixed trim amount independent of the applied reference. This would be accomplished by directing the Trim amount to #1.04 (leaving #1.38=0) and turning #1.09= ON. See Upper Right of diagram above.

## Could this trim amount be adjusted using External Increase/Decrease Buttons ?

*Absolutely !*

We could use yet another built-in function within the drive called the MOP or Motor Operated Pot function. It is not an actual Motorized Pot but rather a software emulation of that function. Refer to Menu 9.

If we wanted a bi-polar +/-10% trim as in the previous example, we would setup the MOP as follows:

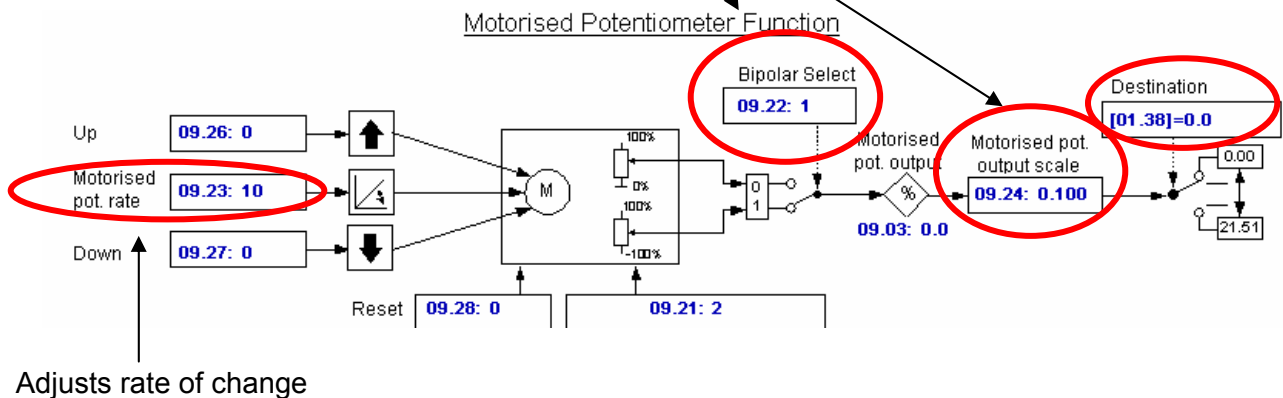

The destination of the MOP output will be directed to our % Trim function just as in the previous analog trim example.

Don't forget to depress the Red Stop button or Reset Drive via CTSoft for the destination assignment to take effect.

At this point, one would only need to assign a free drive input to #9.26 for Increase and another free input to #9.27 for Decrease.

### Other details:

Parameter #9.21 governs some options for the MOP. One may need to review those options and change as necessary.

09.21: 2
Motorised pot. mode
0 - Zero at power up
1 - Last value at power up
2 - Zero at power up only change when running
3 - Last value at power up only change when running

## Could this trim amount be adjusted using an HMI ?

Sure, our drives are particularly good at communicating with any HMI offering Modbus RTU communications.

*One could use one of our economical CTIU Operator Interface units as shown below and ( in keeping with this example ) even have list of preset Ratio recipe call-ups for different product finishes.*

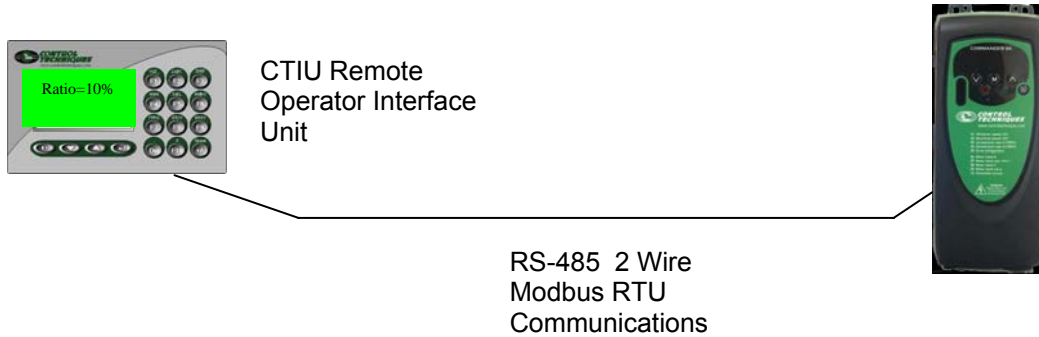

**Questions ?? Ask the Author:**

**Author:** Ray McGranor  
(716)-774-0093

**e-mail :** [ray.mcgranor@emersonct.com](mailto:ray.mcgranor@emersonct.com)