

This Application Note is pertinent to the  
Unidrive SP, Commander SK and GP20 Families

## Creating a Broken Belt/Ruptured Pipe Alarm

### Background

There are applications where one would like to know if there is a mechanical failure in a drive train. For instance, take the application of a VFD running a motor with a fan or pump load. Fans are typically belted to the motor with some pulley ratio. Control Techniques drives have the intelligence and power to determine if a drive belt were to break. It should be noted that similar intelligence could help determine a "ruptured pipe" (or "dry well") in a fluid pumping system. This would be great information to provide a Building Supervisor or Maintenance Service Group.

As a side note, this is the kind of information that our SM-Ethernet module can be set up to send via an email alert (any conditional alarm/fault of one's choice) to anyone on the Internet. Can you imagine getting an alert on your Blackberry or Trio from a drive over the weekend indicating a Broken Belt or Ruptured Pipe even before your clients know about it? Your Blackberry can even allow you to then access the drive via it's built-in webpage server. *Sounds like a good topic for yet another application note !!*

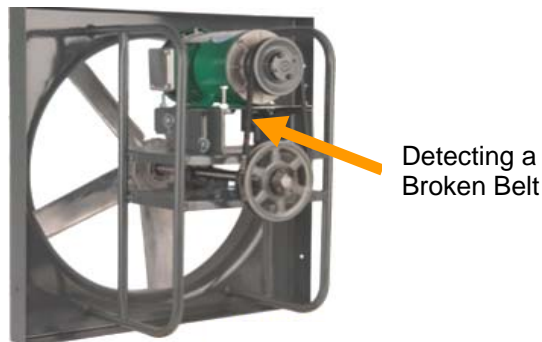

Since most Heating/Cooling and Ventilation Units are placed on the roof of the building, anytime maintenance information that could be obtained without actually going up to the roof and pulling off covers etc- would be a welcomed system attribute that certainly helps make the end product more attractive for both the building owners and maintenance groups.

## Theory of Operation

We all know that the load on a motor goes up exponentially ( as the square of speed ) as the fan speed increases. At low speeds there is very little loading. See plot below.

Speed	%Load
0%	0.0%
10%	1.0%
20%	4.0%
30%	9.0%
40%	16.0%
50%	25.0%
60%	36.0%
70%	49.0%
80%	64.0%
90%	81.0%
95%	90.3%
100%	100.0%

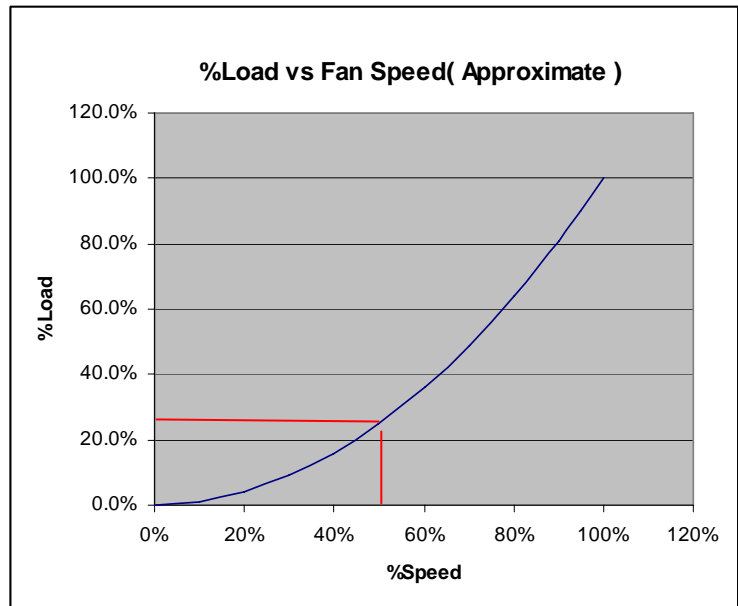

We can see that at 50% speed the load on a fan motor would be approximately 25%. If we decided that our minimum operating speed is 50% of maximum then our motor load should be at least greater than 20%- if the motor was indeed turning a fan. Otherwise we might surmise that the belt has popped off a pulley or just snapped.

In practice one could simply take the motor/fan down to the lowest speed typically ever to be run at and see what the motor load is at that speed. One could surmise that if the load were to fall below this amount ( allowing for some margin of variance ) at this lowest operating speed, that we must have lost our belt- either it broke or popped off the pulley.

Control Techniques drives have several built-in functions lying about that are rarely used which we can configure to create the Broken Belt Detector mentioned above.

The following uses screen shots from our *free* drive configuration tool CTSoft.

Click here to obtain a copy → [CTSoft](#)

# Implementation

What we need is a logic function that solves the verbal logic equation:

**If**  
**Motor Speed is Greater than the Minimum Operating Speed**  
**AND**  
**Motor Load is Greater than what is normally observed at that Speed**  
**Then**  
**Drive Belt/Fluid System appears OK**

However, if the Motor Load is Less than what is normally observed at that Speed

**Then**  
**We want to create an Alarm ( for remote indication )**

We need speed to be involved in the equation because at very low speeds the low load would want to cause an alarm but we know that if the motor speed is below this certain Minimum Operating speed the load will normally be quite low so we are not concerned about this case.

In order to provide us with the intelligence of when the Speed and Load amounts exceed a certain "threshold", this logic can be handled with the functions that are in Menu 12- namely the Threshold Detectors- of which there are two !

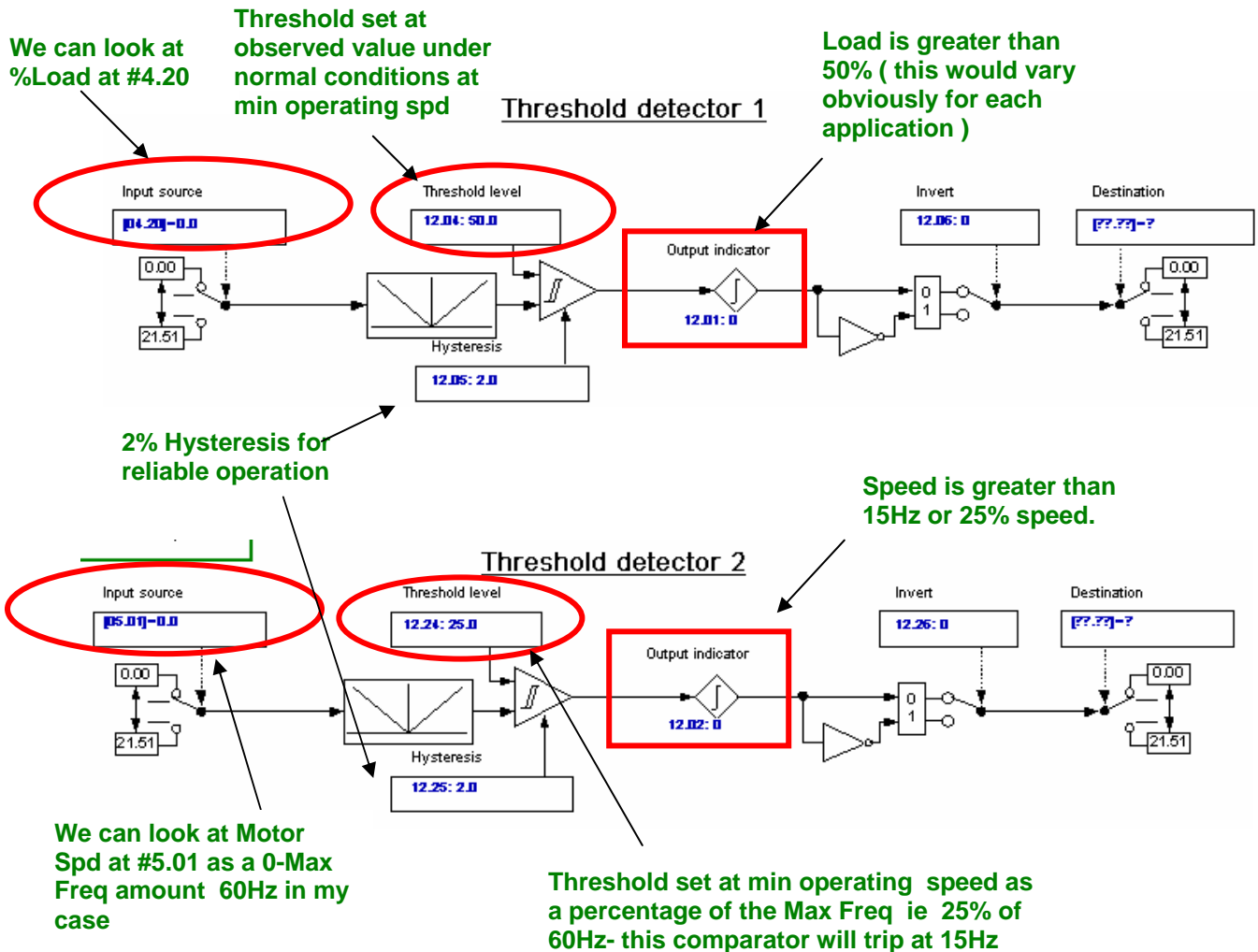

## Now for the Conditional Logical ANDing

As it turns out our drives contain 2 AND gates as well. We should only need one for our needs.

We can pick up the 2 comparator points ( #12.01 and #12.02 ) from the previous diagram ( see the red rectangles )

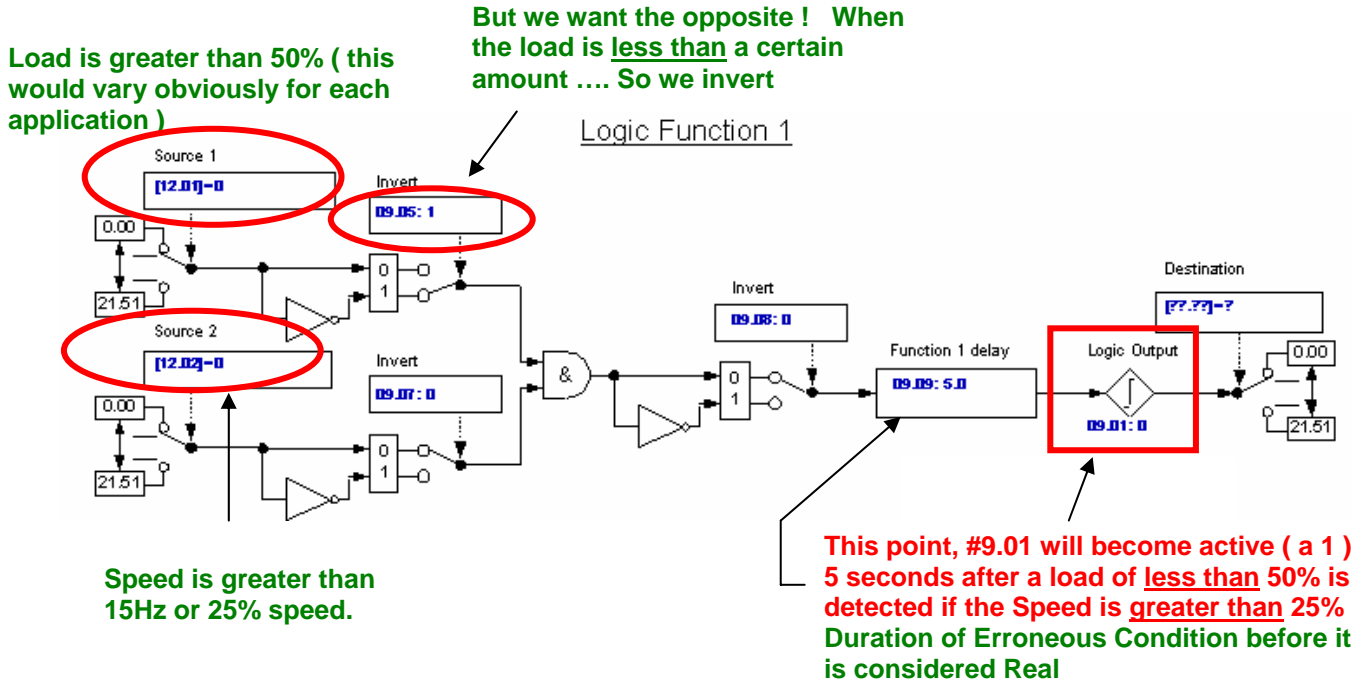

So this should do it ! Now we have an indicator bit, #9.01 that will indicate when we have a broken belt, popped chain, broken pipe or dry well etc.

All we would have to do now is to light a light or turn on a sonic alarm by picking up this point with a relay ( or digital ) output.

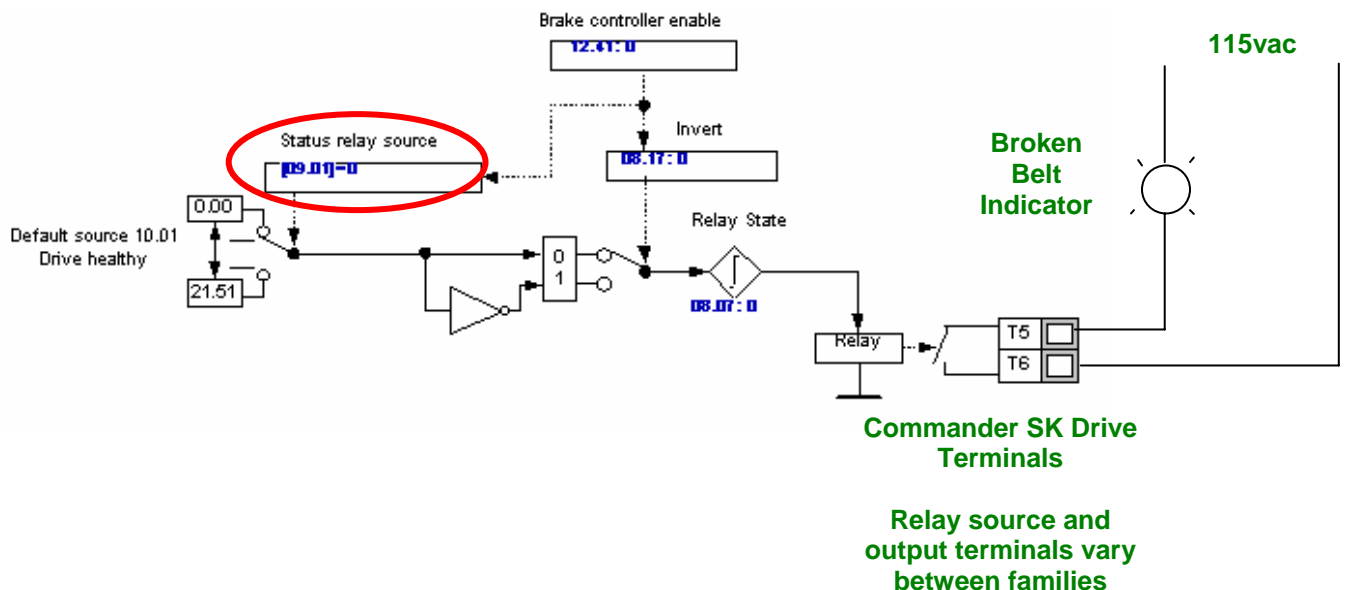

## Embellishment

There is no dispute that a blinking light catches an Operator's eye better than a steady illumination or better yet- a pulsing sonic alarm. In the previous example, we configured one of the programmable outputs for the **Broken Belt** condition to illuminate a lamp, but it would not flash it. Obviously, you could purchase a flasher module of some sort and wire it in to do the job but if you are using our Unidrive SP, Commander GP20, or Affinity, you could create your own flasher within the drive itself at no additional cost! These drives contain a built-in PLC that can be programmed to create a flashing light. The Commander SK can also do this but will require the low cost optional Logic Stick.

Logic Stick→



To see how to do this and even download the program example file ready for use, consult the following SyPT Lite application note by typing into Google or clicking→ [CTSL001](#)  
To use this app note you would use Logic function #2 as shown below:

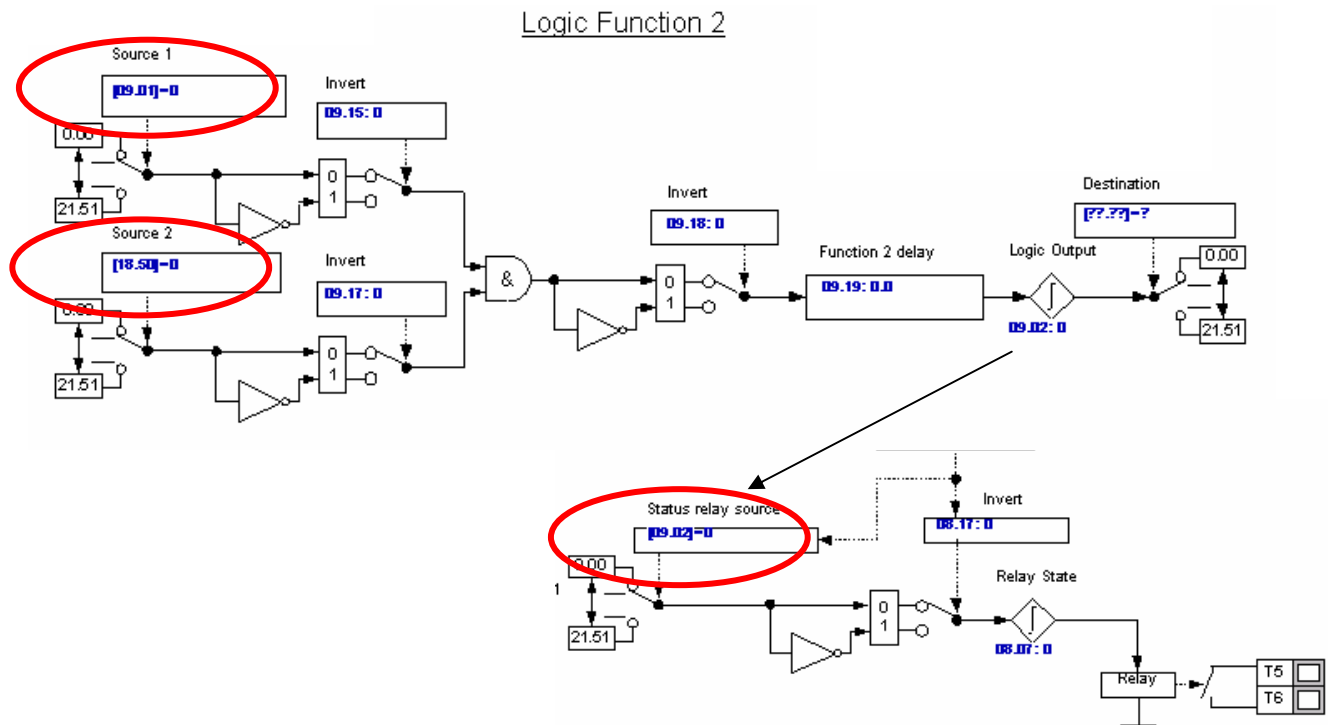

### Authors Note:

By the way, the Affinity has this Low Load/Broken Belt function as a built-in standard. In the case of the Affinity, if you wish a Blinking light for this condition, you could elect to use the SyPT Lite PLC solution or let the drive do it - to see how consult [CTAN 201](#)

Questions ?? Ask the Author:

**Author:** Ray McGranor  
(716)-774-0093  
(800)-367-8067

e-mail : <mailto:ray.mcgranor@emerson.com>