

**This Application Note is pertinent to the Unidrive SP,
Commander SK, GP20 and Affinity Families**

Squeezing a Bit More from your DB Resistor

With AC Drives, Dynamic Braking resistors are often just the ticket to make an application work out where occasional high braking torque is required. Unfortunately they can become expensive especially for higher HP drives. Most DB resistor cages rely on convection cooling. In those cases where one finds that the resistors are getting a bit too hot there would be essentially three options.

1. Replace the DB resistor with one that has a higher wattage/Duty Cycle rating
2. Add additional wattage
3. Blow some cooling air across the cage or resistor element

The first 2 solutions may take some time to implement and maybe be a bit expensive. We all know that if we blew cooling air across/past these resistors they would remain cooler longer and would come back to a quiescent temperature quicker. In fact, with sufficient air flow one could almost double the amount of power dissipation vs relying on pure convection cooling. The problem would be if we employed a fan to blow across these resistors continuously, besides being a waste of energy most of the time, the fan blades and bearing area would tend to get covered with dust and become a definite higher maintenance item. What might be desirable would be to turn on a DB fan as soon as energy is dumped to the DB resistor and have it remain on for maybe 25 seconds (or longer in order to keep the DB resistors from glowing red and making them able to be used again more quickly by dissipating their accumulated energy).

This application note will illustrate a method to sense when the DB resistor has been activated and how to create a Relay output with "Off Delay" to pilot an external DB Fan Cooler for an adjustable time.

Obviously, this application involves the use of a re-triggerable Off Delay. The trigger will be when the DB resistor is activated. The output of the circuit should be able to continue with the cooling effort after the DB resistor had been active and the time should be adjustable by the User. This could be accomplished by employing a hardware based Off Delay Timer but again this may take time to acquire, mount, wire and would cost -- something. It turns out there are facilities inside the drive to create such delays without cost. This is always a preferable solution !

Implementation

We need to know when the DB resistor is being activated. It turns out this is one of the many internal drive status bits available to us. These status bits appear in Menu 10. The DB active bit is #10.11.

Parameter	Description	Default	Memory
10.00	Parameter 0	0	0
10.01	Drive healthy	OFF	OFF
10.02	Drive active	OFF	OFF
10.03	Zero speed	OFF	OFF
10.04	Running at or below minimum speed	OFF	OFF
10.05	Below set speed	OFF	OFF
10.06	At speed	OFF	OFF
10.07	Above set speed	OFF	OFF
10.08	Load reached	OFF	OFF
10.09	Drive output is at current limit	OFF	OFF
10.10	Regenerating	OFF	OFF
10.11	Braking IGBT active	OFF	OFF
10.12	Braking resistor alarm	OFF	OFF
10.13	Direction commanded	FWD	FWD
10.14	Direction running	FWD	FWD
10.15	Mains loss	OFF	OFF
10.16	Under voltage active	OFF	OFF
10.17	Overload alarm	OFF	OFF
10.18	Drive over temperature alarm	OFF	OFF
10.19	Drive warning	OFF	OFF

So, we can use that status bit to trigger an Off Delay. It turns out that we have an On Delay or Off Delay in Menu 9 embedded within an AND gate logic function.

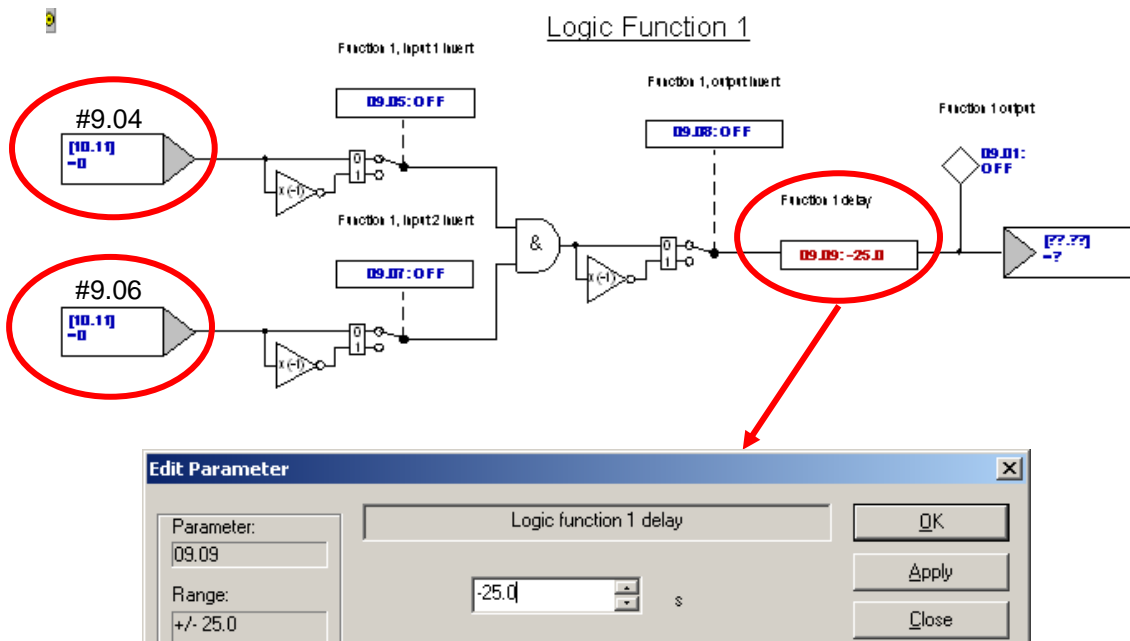

If the delay is positive it is an On-Delay. Negative values will create an Off Delay. The maximum time is limited to 25 seconds. We could string two of these together if we wished longer On- Times of up to 50 seconds. See next page

If you wished Off Delay times of up to 50 seconds you could use the following configuration. It should be noted that these timers are re-triggerable- (that is to say if you keep putting nickels in before the time expires - you get more time before the red flag pops up.)

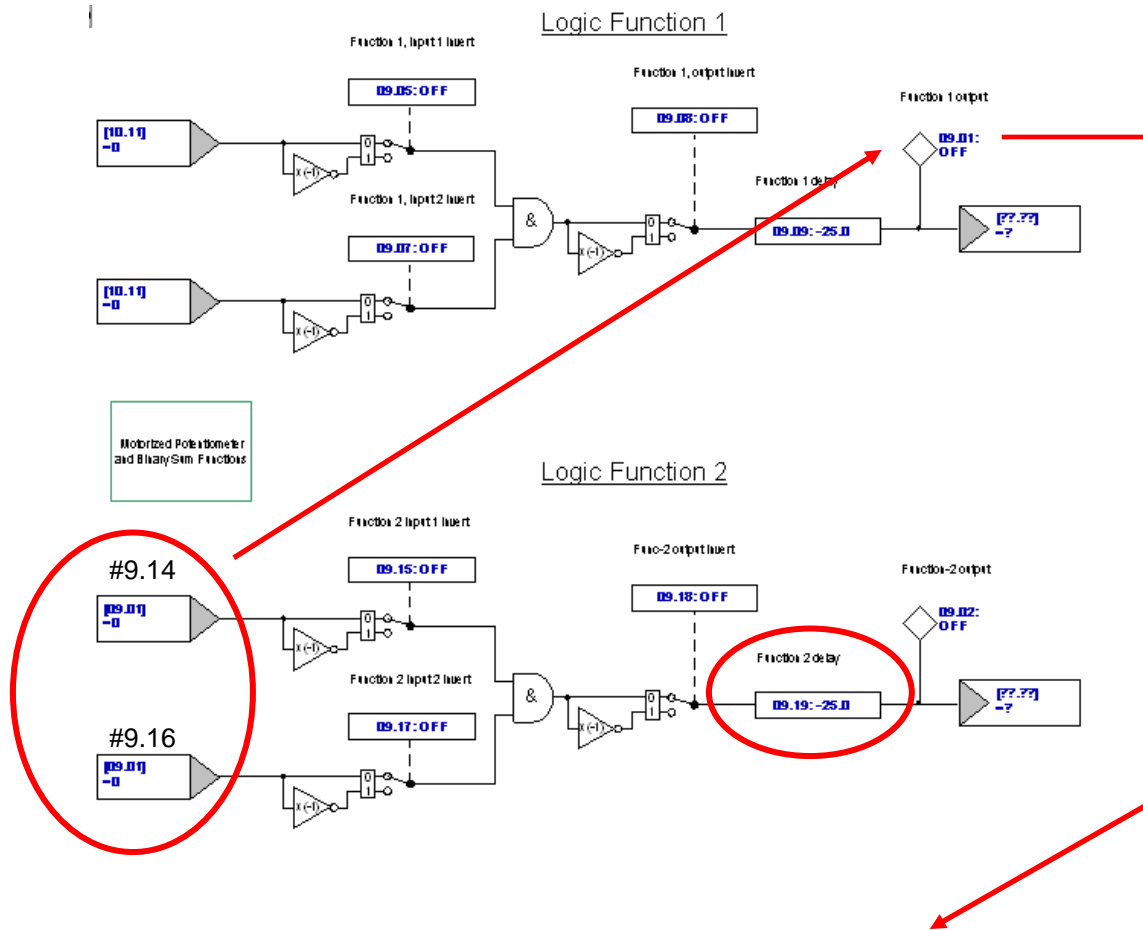

Now for the easy part. All we need is to drive a drive relay from either #9.01 (or #9.02 if we configured for the longer delay). The standard relay within the drive is assignable at #8.27.

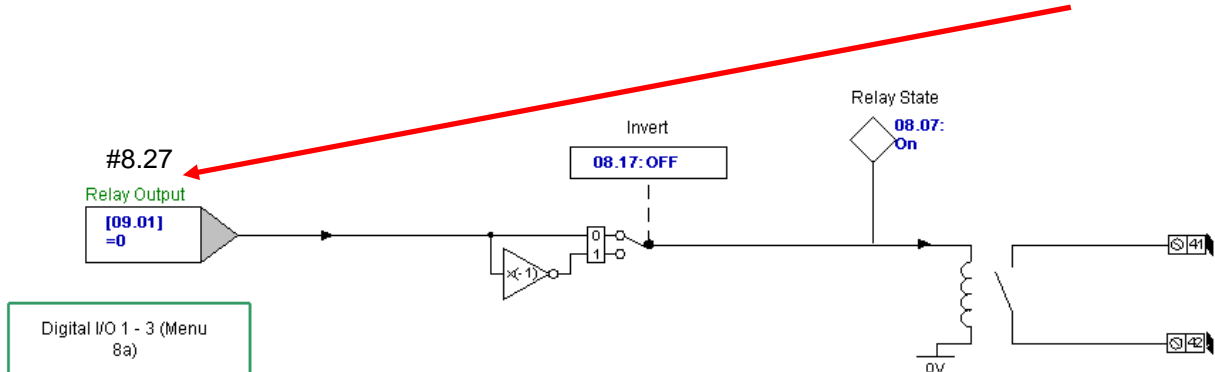

Activate Fan with these contacts –

Consult User Guide for contact rating for the specific drive you are using

The Practical Realities

In some situations, the previous solution may not be ideal. Sometimes after a quick acceleration, an inertial load may actually overshoot in speed which will call for a “short sharp shot” of DB. This will of course trigger the previous circuit. It may not be a problem if the drive then runs at a steady state speed because the fan would run for its period and shut off but if there are speed change requests that trigger the DB, the fan will tend to run almost continuous- which may not be that bad of a thing either.

However, if we wanted, we could ignore short little intermittent bursts of DB until there was a substantial amount of active DB.

The soft circuit below will ignore DB burst of less than 1 second for instance, but if a DB request exceeds 1 second, the second OFF DELAY circuit is triggered for it's adjustable time.

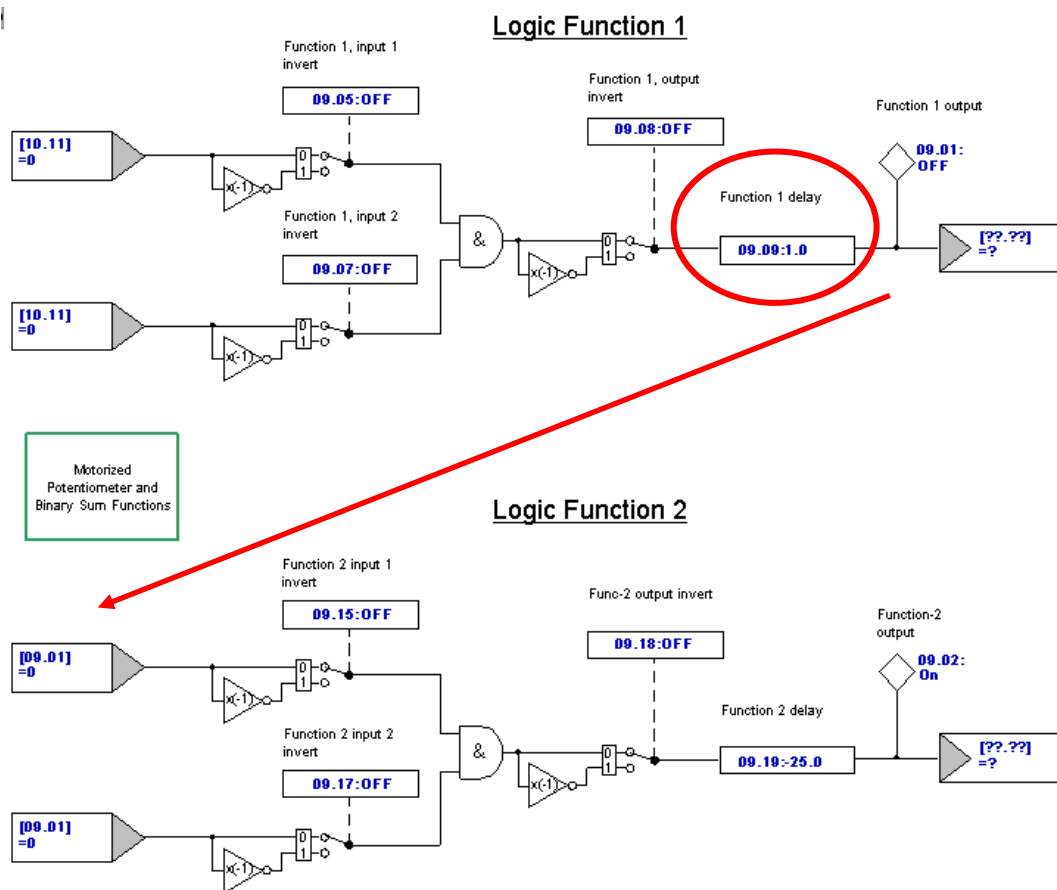

In this example, #9.02 would be used to drive the Relay.

If your built-in Drive Relay is in use you could employ a SM-I/O Lite or I/O Plus Module to obtain another programmable relay.

NOTE

It should be noted that this circuit **in no way protects** the DB resistor **nor is it a solution to possible fire concerns**. This application note only provides a method to keep the DB resistor a bit cooler or allows one to get a little more out of an existing DB resistor -providing the fan continues to work.

For proper DB resistor and fire protection one must either sense excessive resistor heat via an external thermostat mounted in close proximity to the resistors and/or direct measurement of DB resistor current for an I²t - Current x Time Overload device. Either of these devices should be able to drop an AC Input Line Contactor to the drive itself thereby denying further energy to the DB circuit should the DB transistor fail in a shorted manner. Consult the drive User Guide for specific details on this topic.

Questions ?? Ask the Author:

Author: **Ray McGranor**
(716)-774-0093

email: <mailto:ray.mcgranor@emerson.com>