

This Application Note is pertinent to the Unidrive SP,  
Commander SK, GP20 and Affinity Families

### Rudiments of Fieldbus Communications

#### Background

Control Techniques supports a number of popular Fieldbus protocols such as Profibus, Devicenet, Ethernet, Interbus to name a few and more recently BACnet and LON. All of these are quite different but do have several things in common. Basically in our context, a fieldbus is used to communicate information to/from a number of drives in an industrial setting. This implies each drive will have a unique address plus the communication platform and media must be “*industrial strength*” to be reliable in the presence of high electrical noise. In addition, each Fieldbus typically only writes and reads a few pieces of information. In order to facilitate this most typical case, our drives have provisions to streamline this process. We provide a generic Control Word and Status Word that contains the normal things that people typically want to send to a drive or inquire from a drive.

For instance, below is an extract from our DeviceNet Option module guide. A provision that is provided is a standard mapping of 2 polled channels. This consists of 2 Input words (each word is 16bits in length and in this case are part of a 32 bit word) and 2 Output Words. These words contain most commonly used information.

One Input words contain Drive Status info (whether the drive is running, what direction its running etc) The other Input word contains the Commanded Speed after the accel/decel ramp

**Note:** IN words are Inputs to the Fieldbus scanner and  
OUT Words are Outputs from the scanner to the drive.

Table 6.3 Mapping for 2 polled channels

Data word	Slot 1	Slot 2	Slot 3	Default mapping status
IN word 0, 1	Pr 15.10	Pr 16.10	Pr 17.10	Pr 10.40, status word
IN word 2, 3	Pr 15.11	Pr 16.11	Pr 17.11	Pr 2.01, post-ramp speed reference
OUT word 0, 1	Pr 15.20	Pr 16.20	Pr 17.20	Pr 6.42, control word
	Pr 15.21	Pr 16.21	Pr 17.21	Pr 1.21, digital speed reference 1

One OUT word is the Control Word that would allow a PLC or SCADA ( **S**ystem **C**ontrol **A**nd **D**ata **A**cquisition ) system to control the drive Run, Stop, direction etc via communication over this single cable vs discrete Inputs. After the drive is started, one naturally wants to control the speed and this is handled by the other Out word which writes to Preset Speed #1 ( parameter #1.21 ) of our drives.

It should be noted that IN/OUT words are relative to the Communication Master. OUT Words are written commands from the Communication Master, IN Words are requests from the Master typically of status or other inquiries requested from the slave device.

The Control Word (#6.42) for the Unidrive SP ( also GP20 and Affinity ) is defined below :

Bit	Function	Equivalent parameter
0	Drive enable	Pr 6.15
1*	Run forward	Pr 6.30
2*	Jog	Pr 6.31
3*	Run reverse	Pr 6.32
4*	Forward/reverse	Pr 6.33
5*	Run	Pr 6.34
6*	Not stop	Pr 6.39
7	Auto/manual	
8*	Analogue/Presetreference	Pr 1.42
9*	Jog reverse	Pr 6.37
10	Reserved	
11	Reserved	
12	Trip drive	
13	Reset drive	Pr 10.33
14	Keypad watchdog	

These bits will activate the various control bits of the drive- much as the discrete digital inputs do with #6.43 =Off

To permit this control word to control the drive, one must enable the Control Word with #6.43

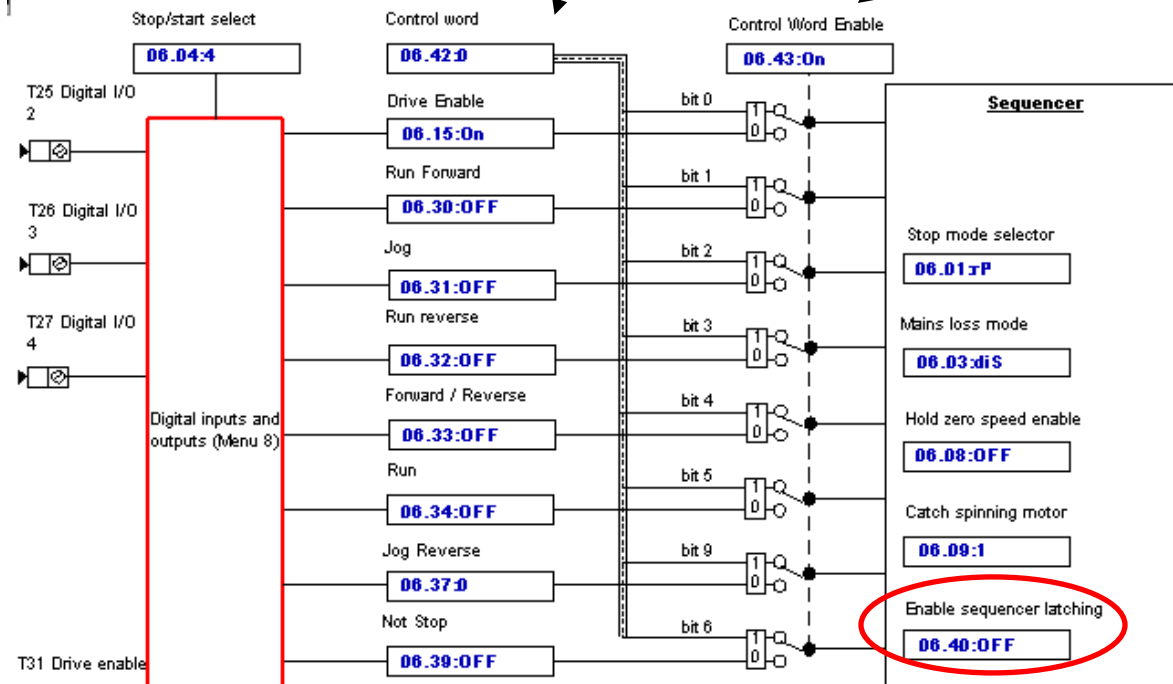

We can investigate how this Control Word works and gain an understanding of what the PLC or SCADA system must need to do in order to command the drive to operate. There is some fine print for bit 7 however.

**Bits 0-7 and bit 9: sequencing control**

When the control word is enabled (Pr 6.43 = 1), and the Auto/manual bit (bit7) are both one, bits 0 to 6 and bit 9 of the control word become active. The equivalent parameters are not modified by these bits, but become inactive when the equivalent bits in the control word are active. When the bits are active they replace the functions of the equivalent parameters. For example, if Pr 6.43 = 1 and bit 7 of Pr 6.42 = 1 the drive enable is no longer controlled by Pr 6.15, but by bit 0 of the control word. If either Pr 6.43 = 0, or bit 7 of Pr 6.42 = 0, the drive enable is controlled by Pr 6.15.

We can begin to construct Control Word for #6.42 by first creating a bit register and populating it with bits.

In order for the Control Word to work at all we must populate bit 7 ( per the pervious fine print paragraph ) and for the drive to work we need the Enable bit as well. So at minimum we could send the drive a Control Word with bit 7 set and then with bit 7 and bit 0 set which becomes

$$\text{Bit-----} \rightarrow \mathbf{7654\ 3210} \quad \mathbf{7654\ 3210}$$

$$1000\ 0001_2 \quad \text{and} \quad 1000\ 0000_2$$

These are in **Binary- base 2**. The Control Word that we will be writing to is expecting a **Decimal** value base 10. So we would need to convert these to decimal. The easiest way to do this is to utilize the Scientific View of the Calculator built-in to Windows.

After opening the Calculator, select View and options as list below. Enter your binary word then click on the Decimal radio button.

Bit	Function	Equivalent parameter
0	Drive enable	Pr 6.15
1*	Run forward	Pr 6.30
2*	Jog	Pr 6.31
3*	Run reverse	Pr 6.32
4*	Forward/reverse	Pr 6.33
5*	Run	Pr 6.34
6*	Not stop	Pr 6.39
7	Auto/manual	
8*	Analogue/Preset reference	Pr 1.42
9*	Jog reverse	Pr 6.37
10	Reserved	
11	Reserved	
12	Trip drive	
13	Reset drive	Pr 10.33
14	Keypad watchdog	

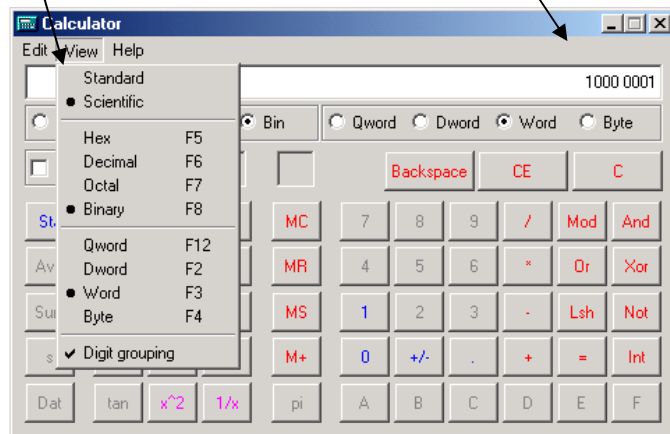

These Control Words become  $129_{10}$  and  $128_{10}$  decimal, respectively.

You must first turn on the Control Word enable #6.43. The drive display should change from **inh** ( 128) to **rdy** ( 129)

If so, you've succeeded at emulating what your Communicating Master must do !

Now we can command the drive to do other things such as Run Forward, Run Reverse, Jog etc by sending the proper Control Word as outlined above.

Prior to doing so, you should setup and prove the drive works properly with your motor and that you have full control. This means that you should have a means of "killing the drive" should you need to. The "kill switch" can be the hardware Drive Enable which can be temporarily accomplished but placing a switch between terminal 22 and 31. Test and verify that it works !!! This would preferably be Push and stay in, Pull out to Enable type of button- but a simple toggle switch would suffice.

Consult CTTN149 for guidance on setting up and running your drive. Click here → [CTTN149](#)

[http://www.emersonct.com/download\\_usa/techNotesMisc/CTTN149.pdf](http://www.emersonct.com/download_usa/techNotesMisc/CTTN149.pdf)

After you have proven that your drive and motor work well together and that your “kill switch” works should you need it, you can emulate Run/Stop/Direction commands as would be sent by your Communicating Master. In order to gain confidence that you understand this one should try this manually to prove it to one’s self.

If you set #0.05 ( or #1.14) = Pr ( setting up to use Preset #1 for speed Reference ), you should be able to continue emulating the Master by trying the following control words. You will need to place a speed value in #0.24 ( or #1.21 ) .

Run Forward would be	1000 0011	= 131 <sub>10</sub>
Run Reverse would be	1000 1001	= 137 <sub>10</sub>
Stop would be	1000 0001	= 129 <sub>10</sub>

**Note:** Parameter #6.40 must be OFF

### Testing your Master

If you have an understanding of the previous discussions, you are ready to check to see if the Master is sending out the correct Control Words. As long as you keep #6.43 = Off the drive will allow you to observe the Control Words but will not respond to them.

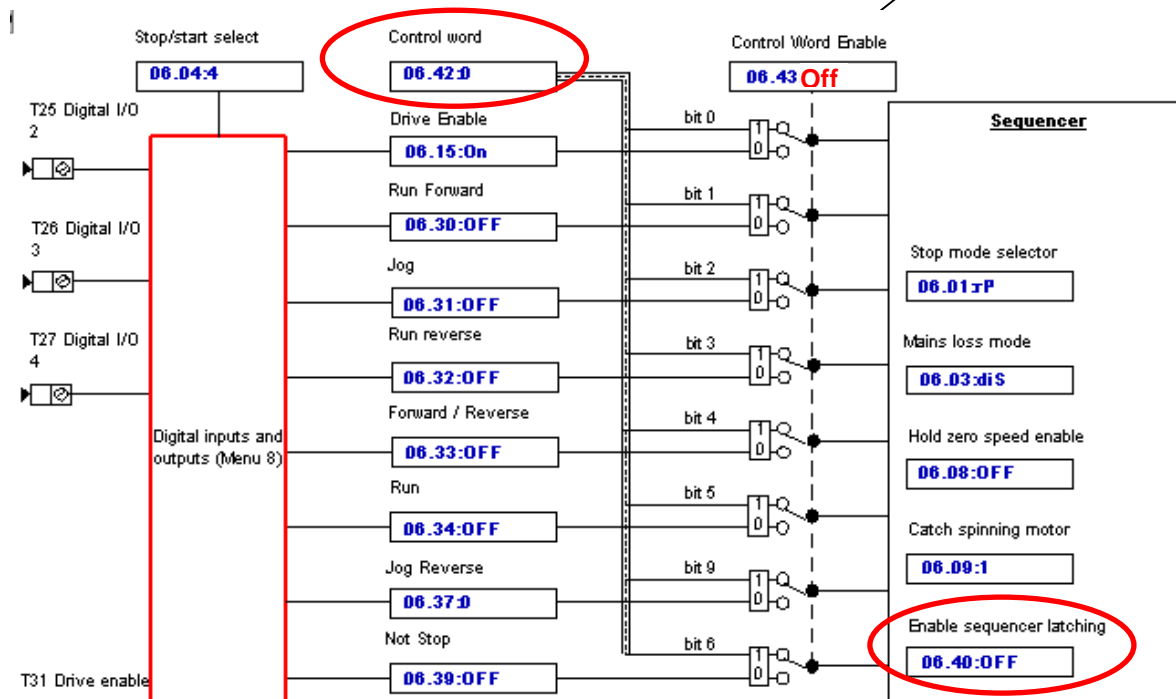

Ensure #6.40 is set to OFF

For instance you know that if your Master commands Run Forward you should observe 131<sub>10</sub> in #6.42 and if your Master commands a Stop you should observe 129<sub>10</sub> . You may also want to look at #1.21 ( the Speed Command setpoint ) to insure that the Master is properly writing the correct speed value.

If all looks fine, you are then ready to set #6.43=On to allow the drive to respond to the Masters serial commands.

# Status Word

Another portion of Fieldbus communication involves the Master requesting and interpreting the drive status. The Unidrive SP, Commander GP20, Commander SK and Affinity all have a Status Word available at parameter #10.40. This status word is a collection of individual status bits available in the drive that when digested ( decoded ) will enable a Communicating Master to make decisions on or display drive activity information. The following is information on contents of that status word.

## Unidrive SP status word

The status word returns the status of multiple functions within the Unidrive SP, e.g. At speed, Zero speed, Drive healthy, etc., and provides a quick method of checking the current status of the Unidrive SP. The status word is mapped to cyclic data as Pr 10.40.

<b>b15</b>	<b>b14</b>	<b>b13</b>	<b>b12b</b>	<b>b11</b>	<b>b10</b>	<b>b9</b>	<b>b8</b>
Not Used	Pr 10.15	Pr 10.14	Pr 10.13	Pr 10.12	Pr 10.11	Pr 10.10	Pr 10.09
<b>b7</b>	<b>b6</b>	<b>b5</b>	<b>b4</b>	<b>b3</b>	<b>b2</b>	<b>b1</b>	<b>b0</b>
Pr 10.08	Pr 10.07	Pr 10.06	Pr 10.05	Pr 10.04	Pr 10.03	Pr 10.02	Pr 10.01

The table below shows the function indicated by each bit in the status word when set to 1. A bit set to 0 indicates that the condition is false.

**Table 8.1 Unidrive SP status word bit functions**

Bit	Parameter	Description
0	Pr 10.01	<b>Drive healthy</b> Indicates the Unidrive SP is not in the trip state. If the auto-reset feature is being used, this bit is not reset until all auto-resets have been attempted and the next trip occurs.
1	Pr 10.02	<b>Drive active</b> Indicates that the output stage of the Unidrive SP is active.
2	Pr 10.03	<b>Zero speed</b> In Open Loop mode, zero speed indicates that the absolute value of the post-ramp speed reference (Pr 2.01) is at or below the zero speed threshold defined by Pr 3.05. In Closed Loop and Servo modes, zero speed indicates that the absolute value of speed feedback (Pr 3.02) is at or below the zero speed threshold defined by Pr 3.05.
3	Pr 10.04	<b>Running at or below minimum speed</b> In bipolar mode (Pr 1.10 = 1) Pr 10.04 is the same as zero speed, Pr 10.03. (See above.) In unipolar mode, Pr 10.04 is set if the absolute value of the post-ramp speed reference (Pr 2.01) or speed feedback (Pr 3.02) is at or below minimum speed + 0.5Hz or 5rpm. (Minimum speed is defined by Pr 1.07.) This parameter is only set if the Unidrive SP is running.
4	Pr 10.05	<b>Below set speed</b> Only set if the Unidrive SP is running. Refer to Pr 3.06, Pr 3.07 and Pr 3.09 in the <i>Unidrive SP Advanced User Guide</i> .
5	Pr 10.06	<b>At speed</b> Only set if the Unidrive SP is running. Refer to Pr 3.06, Pr 3.07 and Pr 3.09 in the <i>Unidrive SP Advanced User Guide</i> .
6	Pr 10.07	<b>Above set speed</b> Only set if the Unidrive SP is running. Refer to Pr 3.06, Pr 3.07 and Pr 3.09 in the <i>Unidrive SP Advanced User Guide</i> .
7	Pr 10.08	<b>Load reached</b> Indicates that the modulus of the active current is greater or equal to the rated active current, as defined in menu 4. Refer to the <i>Unidrive SP Advanced User Guide</i> for more details.
8	Pr 10.09	<b>In current limit</b> Indicates that the current limits are active.



Bit	Parameter	Description
9	Pr 10.10	<b>Regenerating</b> In Open Loop, Closed Loop and Servo modes, regenerating indicates that power is being transferred from the motor to the Unidrive SP. In Regen mode, regenerating indicates that power is being transferred from the supply to the Unidrive SP.
10	Pr 10.11	<b>Dynamic brake active</b> Indicates that the braking IGBT is active. If the IGBT becomes active, this parameter will remain on for at least one second.
11	Pr 10.12	<b>Dynamic brake alarm</b> Dynamic brake alarm is set when the braking IGBT is active, and the braking energy accumulator is greater than 75%.
12	Pr 10.13	<b>Direction commanded</b> Direction commanded is set to 1 if the Pre-ramp speed reference (Pr 1.03) is negative, and reset to 0 if the Pre-ramp speed reference is zero or positive.
13	Pr 10.14	<b>Direction running</b> In Open Loop mode, direction running is set to 1 if the post-ramp speed reference (Pr 2.01) is negative, and reset to 0 if the post-ramp speed reference is zero or positive. In Closed Loop Vector and Servo modes, direction running is set to 1 if the Speed Feedback (Pr 3.02) is negative and reset to 0 if the speed feedback is zero or positive.
14	Pr 10.15	<b>Mains loss</b> In Open Loop, Closed Loop Vector and Servo modes, mains loss indicates that the drive has detected mains loss from the level of the DC bus voltage. This parameter can only become active if mains loss ride through or mains loss stop modes are selected. Refer to Pr 6.03 in the <i>Unidrive SP Advanced User Guide</i> the for more details. In Regen mode, mains loss is the inverse of Pr 3.07. Refer to the <i>Unidrive SP Advanced User Guide</i> the for more details.
15	Not Used	Reserved

## Status Word Decode Example

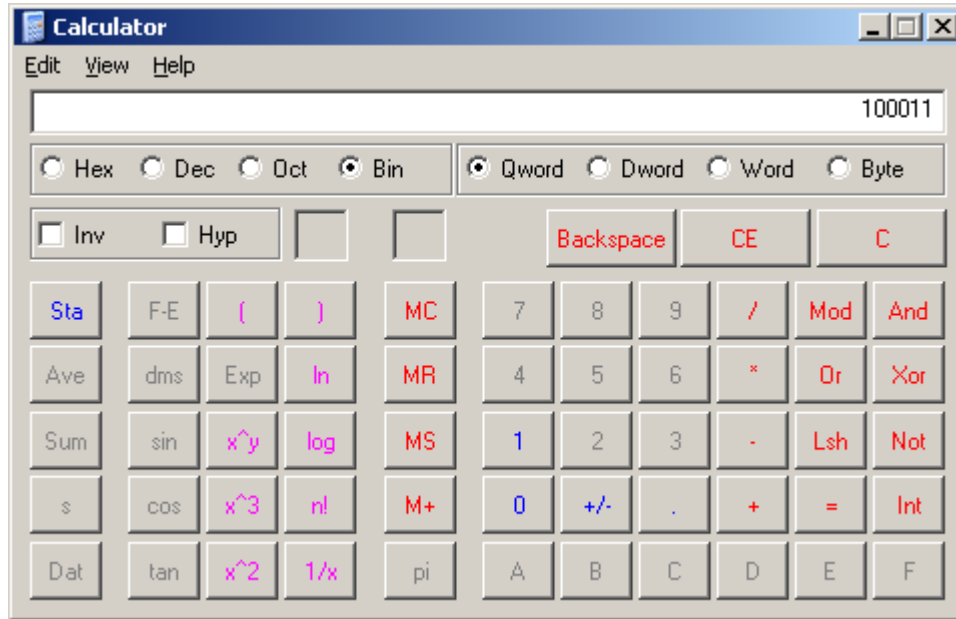
If we were to look at #10.40 and see 35, this is a decimal number  $35_{10}$  base 10. In order to decode this we would need to convert to binary. Putting the decimal number into the calculator the binary conversion is :



This will decode as follows:

<b>Status Word #10.40 =</b> <input type="text" value="35"/>	<b>Bit 6</b> <input type="checkbox"/> <b>Above Set Speed</b>
<input type="button" value="Exit"/>	<b>Bit 5</b> <input checked="" type="checkbox"/> <b>At Speed</b>
	<b>Bit 4</b> <input type="checkbox"/> <b>Below Set Speed</b>
	<b>Bit 3</b> <input type="checkbox"/> <b>Running at or below speed</b>
<b>For technical support please call 800-367-8067 or visit us on the internet at <a href="http://www.emersonct.com">www.emersonct.com</a></b>	<b>Bit 2</b> <input type="checkbox"/> <b>Zero Speed</b>
	<b>Bit 1</b> <input checked="" type="checkbox"/> <b>Drive Active</b>
	<b>Bit 0</b> <input checked="" type="checkbox"/> <b>Drive Healthy</b>

Questions ?? Ask the Author:

**Author:** Ray McGranor  
(716)-774-0093

**email:** <mailto:ray.mcgranor@emerson.com>