

This Application Note is pertinent to the Unidrive SP,
Commander SK, GP20 and Affinity Families

Obtaining the Greater or Lesser of Two Signals

Background

Sometimes a control scheme needs to use the greater of 2 input signals in order to maintain optimal system control. Other times the scheme may require the lesser of 2 input signals to be used. Developing a SyPT Lite program to accomplish this mathematical comparison and signal steering would be rather trivial but as it turns out there are facilities within the drive that can be used to accomplish this functionality using simple drive configuration assignments.

This application note will outline a method of bringing in two analog signals and allowing one to direct either the larger or the lesser of the signals to their desired destination.

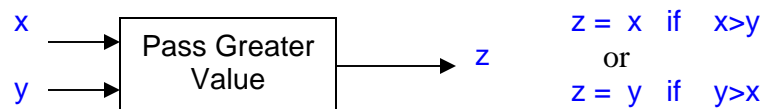

This application note illustrates how to accomplish this function using CTSOft block diagram “*screenshots*”. This function can be achieved using a Comparator and Variable Selectors in Menu 12 of our drives.

Application #1

An obvious application might be where one wants redundant feedback to a PID loop for instance.. Should either feedback device fail, the working one would bumplessly take over providing continuous feedback to prevent a runaway or even an intermittent burp in the control system.

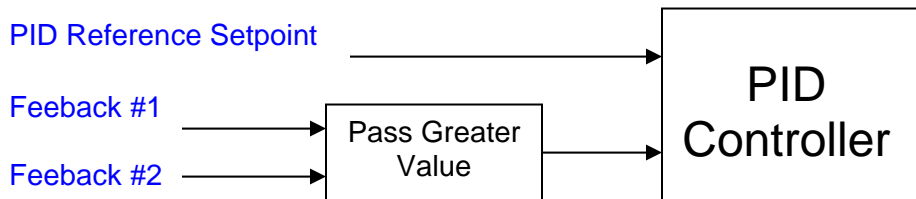

Implementation

Two analog inputs are being excited with signals as shown below. Their values can be observed in #7.01 and #7.02.

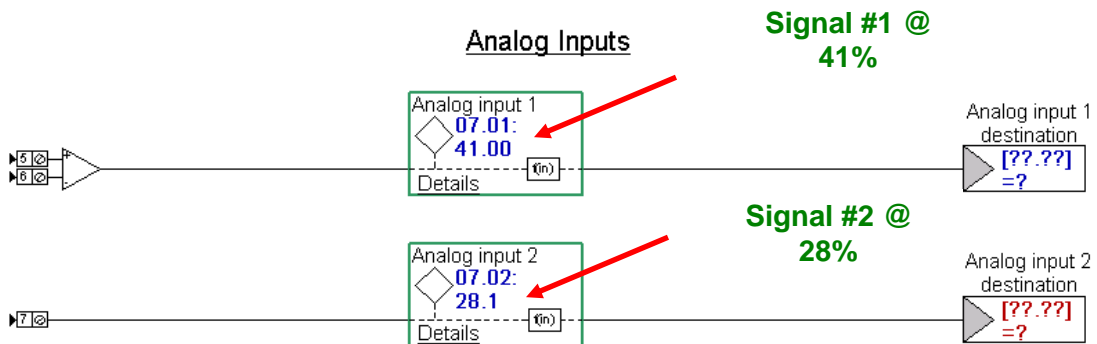

Get Analog #1 w/ #12.08

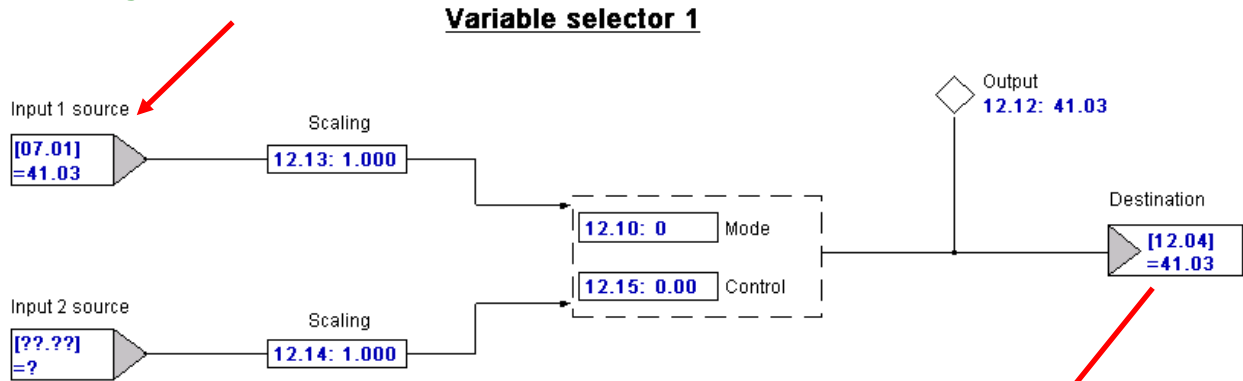

The circuit above merely provides a method to redirect one of the analog values to a Comparator

Threshold detector 1

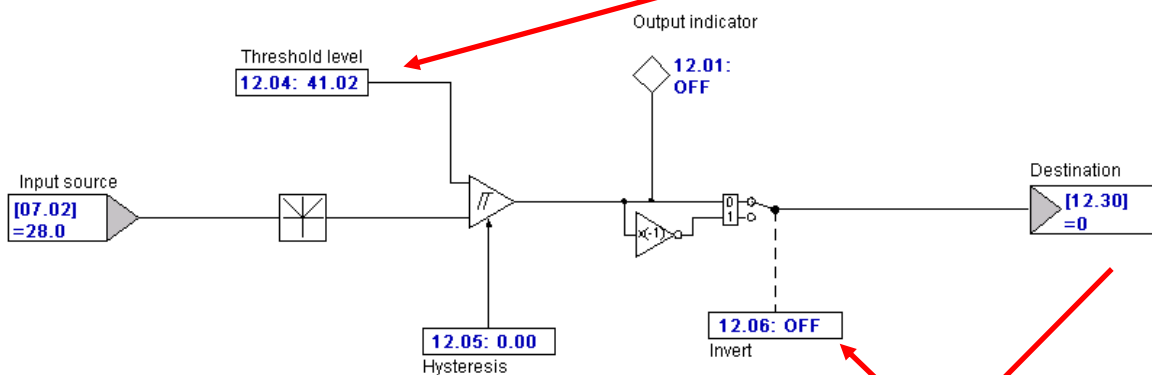

The circuit performs the magnitude comparison of Analog #1 against Analog #2 (#7.02 in this case)
 If Analog #1 is > Analog #2 then #12.01 =0
 If Analog #1 is < Analog #2 then #12.01 =1
 This result (#12.01) is directed to the circuit below to #12.30

Analog Input #1



Analog Input #2



Variable selector 2



The circuit above will output the GREATER of the 2 Analog Inputs (observable at #12.32)

NOTE: If one wishes the LESSER of the 2 Analog Input you would merely need to Invert (or turn ON) #12.06

This is the alternate case where Input #2 is the greater value

Analog Input #1

Input 1 source

[07.01]
=41.03

Scaling

12.33: 1.000

Variable selector 2

Analog Input #2

Input 2 source

[07.02]
=50.9

Scaling

12.34: 1.000

12.30: 1 Mode

12.35: 0.00 Control

Output

12.32: 50.80

Destination

[??.??]
=?

One would just insert the destination (or where you wish this result) to go.

Application #2

Another typical application of such a function is to create a minimum setting (or maximum if lesser scheme is used).

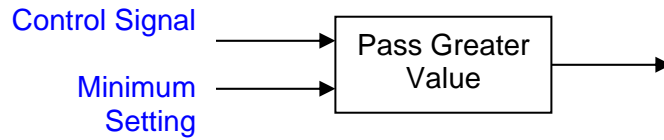

Implementation

Let's say we want to limit an analog input value to not fall below 25%. We can create a 25% value in the free register Menu 18 area using say parameter #18.11. These registers can hold a value of 32767 which would equal 100% - so 25% would be $\frac{1}{4}$ of 32767 or 8192.

Parameter	Description	Default	Memory
18.00	Parameter 0	0	0
18.01	Application menu 1 power-down saved i...	0	0
18.02	Application menu 1 read-only integer	0	0
18.03	Application menu 1 read-only integer	0	0
18.04	Application menu 1 read-only integer	0	0
18.05	Application menu 1 read-only integer	0	0
18.06	Application menu 1 read-only integer	0	0
18.07	Application menu 1 read-only integer	0	0
18.08	Application menu 1 read-only integer	0	0
18.09	Application menu 1 read-only integer	0	0
18.10	Application menu 1 read-only integer	0	0
18.11	Application menu 1 read-write integer	0	8192
18.12	Application menu 1 read-write integer	0	0

We would direct this value to the Comparator Level located at #12.04 using the Variable selector. When the mode is 0 (#12.10) the selector selects the value at Input 1.

Variable selector 1

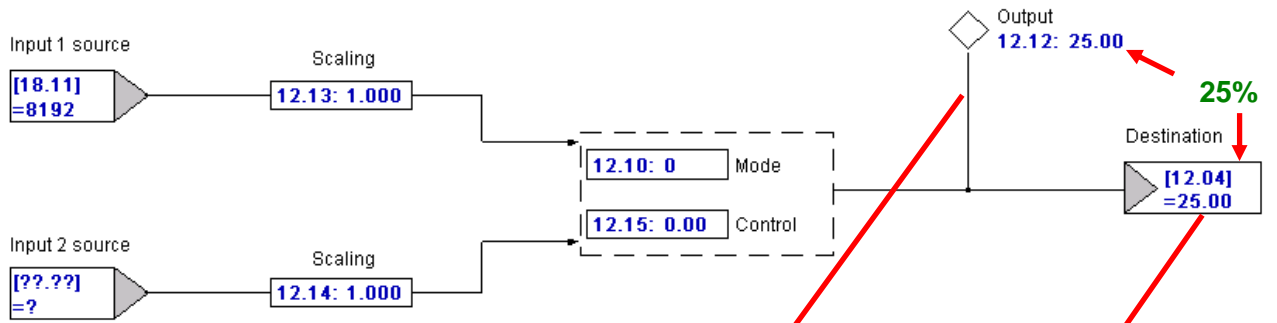

Threshold detector 1

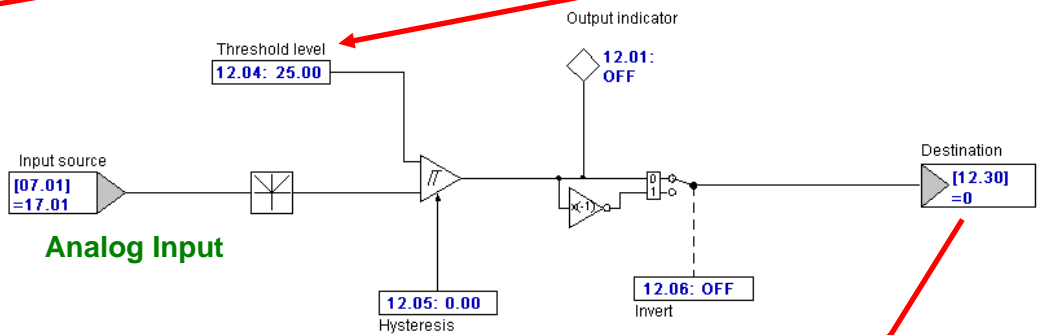

Variable selector 2

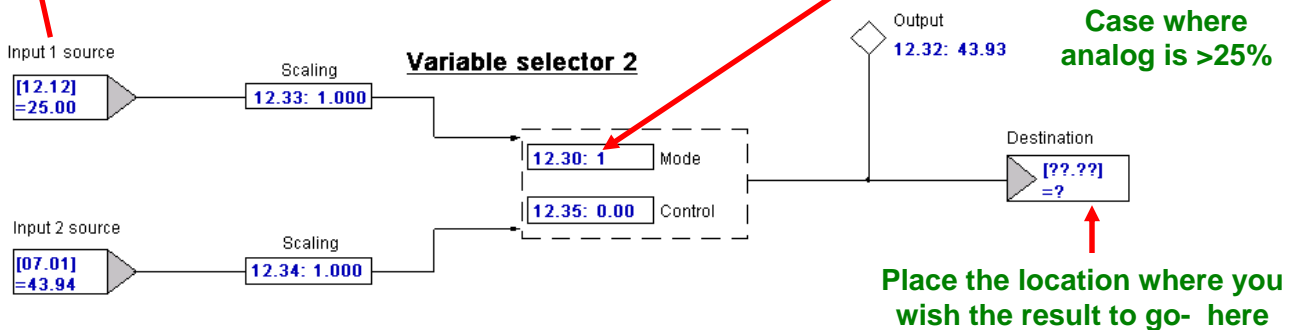

Analog Input

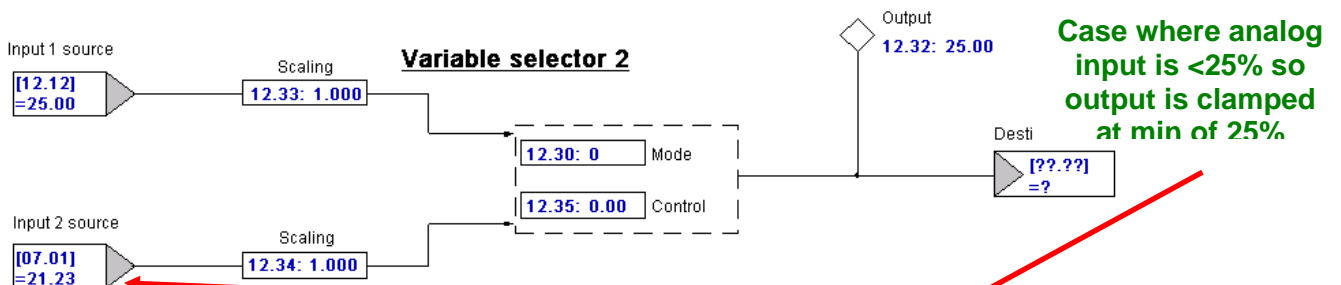

Graphical View of Results

The red trace is the analog input signal and the blue trace is the resultant whereby the output is the analog signal unless it falls below 25% where the result is capped at the minimum of 25%.

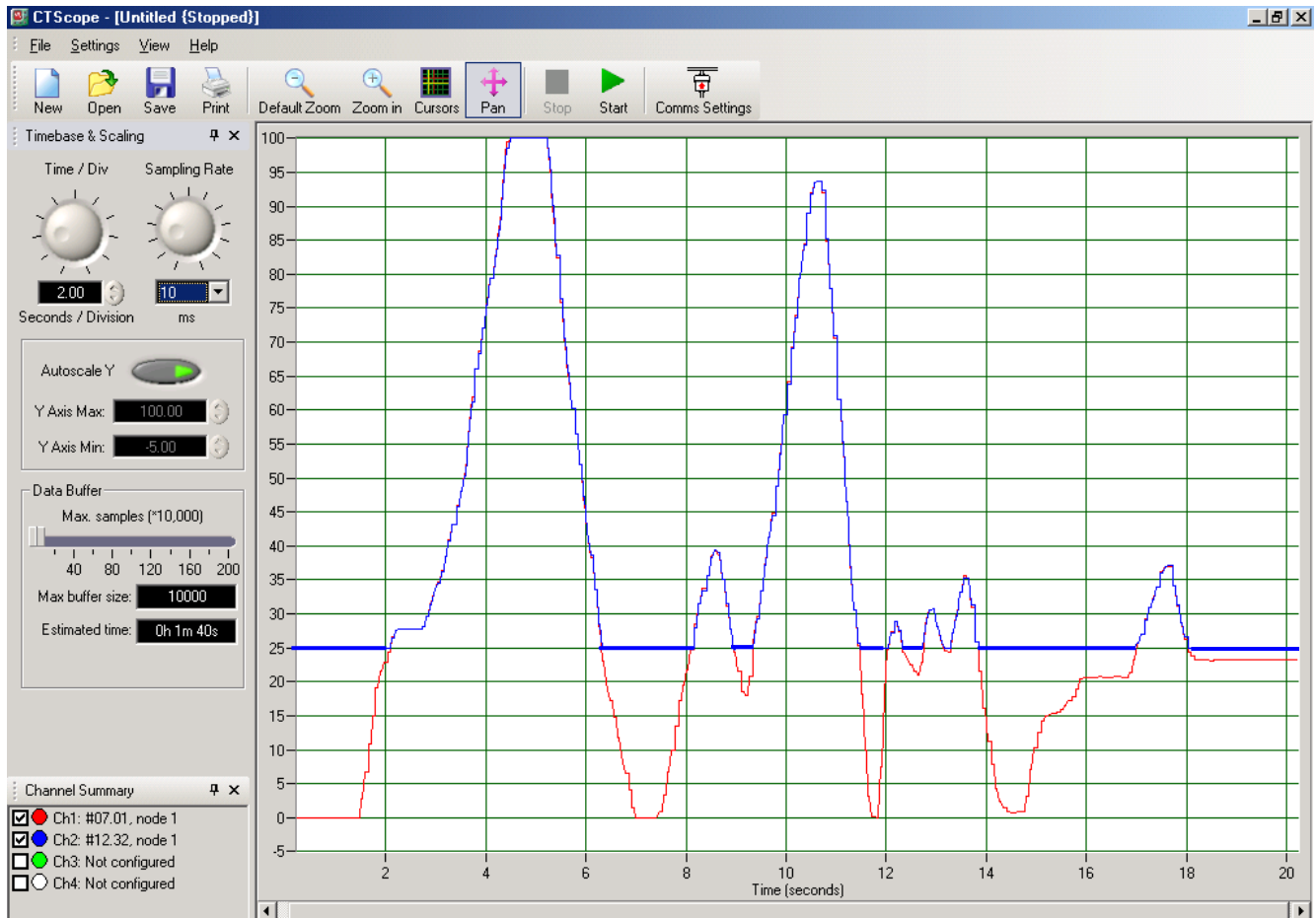

The screenshot above was taken directly from CTScope.

CTScope and CTSoft are available free of charge by clicking on the links below

[**CTSoft**](#)

[**Four Channel Color Scope**](#)

Questions ?? Ask the Author:

Author: Ray McGranor
(716)-774-0093

email: <mailto:ray.mcgranor@emerson.com>